 在本使用说明书中，我们将尽力叙述各种与 **GSK ZJY** 系列主轴伺服电动机相关的事项。限于篇幅限制及产品具体使用等原因，不可能对所有不必做和/或不能做的操作进行详细的叙述。因此，本使用说明书中没有特别指明的事项均视为“不可能”或“不允许”进行的操作。

 本使用说明书的版权，归广州数控设备有限公司所有，任何单位与个人进行出版或复印均属于非法行为，广州数控设备有限公司将保留追究其法律责任的权利。

前 言

尊敬的客户：

对您惠顾选用广州数控设备有限公司的 GSK ZJY 系列主轴伺服电动机（以下简称电动机），本公司深感荣幸并深表感谢！

为了保证电动机产品安全、正常与有效地运行工作，请您务必在安装、使用产品前仔细阅读本使用说明书。

安全警告及注意事项



连接及操作不当，将引起意外事故！
请使用操作之前务必仔细阅读本使用说明书。

- 1 电动机内装有光电编码器，安装时严禁敲打电动机；用户不得自行拆装光电编码器，否则破坏编码器而致使电动机无法运行！
- 2 在正常气候条件下，用 **1000V** 兆欧表测量电动机绕组对机壳的绝缘电阻，其值应不小于 **20 MΩ**。
- 3 按本使用说明书所述的电动机与驱动单元接线方式正确连接，确保保护接地连接牢固可靠。
- 4 电动机从零速至最高速空载运行，应无异常噪声和震动，方可投入负载运行。
- 5 电动机运行中，切勿接触运转中的电动机轴以及电动机外壳。
- 6 具有相应资格的人员，才能调整、维护电动机。
- 7 不得拖拽电线(缆)、电动机轴和编码器搬运伺服电机。
- 8 用户对产品的任何改动本公司将不承担任何责任，产品的保修单将因此作废。

所有规格和设计如有变化，本公司恕不另行通知。

安 全 责 任

制造者的安全责任

- 制造者应对所提供的电动机及随行供应的附件在设计和结构上已消除和/或控制的危险负责。
- 制造者应对所提供的电动机及随行供应的附件的安全负责。
- 制造者应对提供给使用者的使用信息和建议负责。

使用者的安全责任

- 使用者应通过电动机安全操作的学习和培训，并熟悉和掌握安全操作的内容。
- 使用者应对自己增加、变换或修改原电机、附件后的安全及造成的危险负责。
- 使用者应对未按使用说明文件的规定操作、调整、维护、安装和储运产品造成的危险负责。

本手册由最终用户收藏。

诚挚的感谢——您在使用广州数控设备有限公司的产品时，
对我们的友好支持！

目 录

一	产 品 特 点	1
二	工 作 运 行 环 境	1
三	电 动 机 型 号 说 明	2
四	电 动 机 的 主 要 技 术 参 数 及 外 形 尺 寸	3
五	电 动 机 机 械 特 性 曲 线	12
六	电 动 机 的 连 接 及 安 装	22
七	电 动 机 的 贮 存	24
八	电 动 机 的 运 输	24
九	质 量 保 证 期	25

一 产品特点

GSK ZJY 系列主轴伺服电动机是广州数控设备有限公司自主开发及制造的新型高性能三相感应电动机，采用 F 级绝缘结构、变频电机专用耐电晕漆包线，使用高速、高精度编码器。产品具有结构紧凑、旋转精度高、噪声低、可靠性高、性能价格比高等特点，能广泛满足机床数控及自动化等有关需求。



二 工作运行环境

- 2.1 海拔不应超过 1000m。
- 2.2 环境温度在 $-10^{\circ}\text{C} \sim +40^{\circ}\text{C}$ 的范围内。
- 2.3 空气相对湿度 $\leq 90\%$ （无凝露）。
- 2.4 AC 稳态电压值为： $(0.9 \sim 1.1) \times \text{AC 额定电压值}$ 。

三 电动机型号说明

示例：**ZJY208A-5.5BH-B5A1LY1-L**

ZJY	208	A	-	5.5	B	H	-	B5	A1	L	Y1	(**)	-	L
(1)	(2)	(3)		(4)	(5)	(6)		(7)	(8)	(9)	(10)	(11)		(12)

序号	含 义
(1)	主轴伺服电动机
(2)	机座号 (182、208、265)
(3)	设计序号 (无: 原始, A、B、C……: 设计序号)
(4)	额定功率 (单位 kW)
(5)	额定转速 (T: 300 r/min、U: 450 r/min、V: 600 r/min、W: 750 r/min、 A: 1000 r/min、B: 1500 r/min、C: 2000 r/min、D: 2500 r/min、E: 3000 r/min)
(6)	最高转速 (F: 12000 r/min、H: 10000 r/min、M: 7000 r/min、L: 4500 r/min)
(7)	结构安装型式: (B5 凸缘安装、B3 底脚安装、B35 凸缘底脚安装)
(8)	编码器类型 (无: 增量式 1024 p/r、A: 增量式 2500p/r、A1: 4096 p/r、 A2: 增量式 5000 p/r、A4: 绝对式 17 bit、A8: 绝对式 19 bit)
(9)	从轴伸端看接线盒位置 (无: 接线盒顶置、R: 接线盒右置、L: 接线盒左置)
(10)	轴伸 (无: 光轴、Y1: 带标准键槽)
(11)	客户特殊订货代号, 用两个大写字母加括号表示
(12)	电源电压 (无: 三相 380~440V、L: 三相 220V)

注: ZJY182-3.7BM、ZJY208A-5.5BL 和 ZJY208A-7.5BL 编码器类型只有增量式 1024 p/r。

产品特点

- ◇ 采用全封闭式无外壳风冷结构, 外形美观、结构紧凑
- ◇ 采用优化的电磁设计, 电磁噪声低、运行平稳、效率高
- ◇ 采用进口高精度轴承和转子高精度动平衡工艺, 确保电动机运行在最高转速范围内稳定可靠、振动小、噪声低
- ◇ 采用耐电晕漆包线, 电动机能在-15℃~40℃环境温度及粉尘油雾环境下可靠使用
- ◇ 采用高速、高精度编码器, 与高性能驱动单元配合可作高精度的速度和位置控制
- ◇ 过载能力强, 可 30min 150%额定功率下、5min 300%额定功率下可靠运行
- ◇ 调速范围广, 最高转速可达 12000r/min
- ◇ 耐冲击, 寿命长, 性能价格比高。
- ◇ 防护等级: IP54 (GB/T 4942.1—2006)
- ◇ 绝缘等级: F 级 (GB 755—2008)
- ◇ 振动等级: B 级 (GB 10068—2008)

四 电动机的主要技术参数及外形尺寸

4.1 三相 380~440V 主轴电动机主要技术参数及外形尺寸见表 1。

表 1

规格 项目	ZJY182-1.5BH	ZJY182-2.2BH	ZJY182-2.2CF	ZJY182-3.7BH	ZJY182-3.7DF	ZJY182-5.5CF	ZJY182-7.5EH	ZJY182-3.7BM	ZJY208A-3.7WL	
额定功率 (kW)	1.5	2.2	2.2	3.7	3.7	5.5	7.5	3.7	3.7	
适配 GS 驱动器型号	GS3048Y	GS3048Y	GS3050Y	GS3050Y	GS3050Y	GS3075Y	GS3100Y	GS3050Y	GS3050Y	
驱动单元电源 (V)	三相 AC 380~440V 50/60Hz									
额定电流 (A)	7.3	7.5	9	15.5	13	19	21	10.4	11.3	
额定频率 (Hz)	50	50	69	50	87	70	100	50	25	
额定转矩 (N·m)	9.5	14	10.5	24	14	26	24	24	47	
30min 功率 (kW)	2.2	3.7	3.7	5.5	5.5	7.5	11	5.5	5.5	
30min 电流 (A)	9.3	11	14.6	19.6	19	25	30	14.8	16	
30min 转矩 (N·m)	14	24	17.7	35	21	37	35	35	70	
额定转速 (r/min)	1500	1500	2000	1500	2500	2000	3000	1500	750	
恒功率范围 (r/min)	1500~8000	1500~8000	2000~10000	1500~8000	2500~10000	2000~10000	3000~9000	1500~5000	750~3000	
最高转速 (r/min)	10000	10000	12000	10000	12000	12000	10000	7000	4500	
转动惯量 (kg·m ²)	0.0056	0.0074	0.0056	0.0115	0.0074	0.0115	0.0115	0.0093	0.0309	
重量 (kg)	27	32	27	43	32	43	43	37	77	
安装型式	IM B5 或 B35									
冷却风机电源	三相 AC 380~440V 50/60Hz 37W 0.1A								三相 AC 380~440V 50/60Hz 40W 0.14A	
外形尺寸 (见图)	A	182	182	182	182	182	182	182	182	208
	B	91	91	91	91	91	91	91	91	104
	C	126	126	126	126	126	126	126	126	160
	D	185	185	185	185	185	185	185	185	215
	E	60	60	60	60	60	60	60	60	80
	F	324	351	324	406	351	406	406	376	524
	G	198	225	198	280	225	280	280	250	395
	H	150h7	150h7	150h7	150h7	150h7	150h7	150h7	150h7	180h7
	I	12	12	12	12	12	12	12	12	14
	J	28h6	28h6	28h6	28h6	28h6	28h6	28h6	28h6	38h6
	K	184	184	184	184	184	184	184	184	212
	L	93	93	93	93	93	93	93	93	106
	N	156	156	156	156	156	156	156	156	180
	P	32	32	32	32	32	32	32	32	40
	Q	132	159	132	214	159	214	214	184	320
	S	60	60	60	60	60	60	60	60	80
T	4	4	4	4	4	4	4	4	5	
Z	12	12	12	12	12	12	12	12	12	

表 1 (续)

规格 项目	ZJY208A-2.2AM	ZJY208A-3.7AM	ZJY208A-5.5AM	ZJY208A-2.2BH	ZJY208A-3.7BH	ZJY208A-5.5BH	ZJY208A-7.5BH	ZJY208A-3.7BM	ZJY208A-5.5BM
额定功率 (kW)	2.2	3.7	5.5	2.2	3.7	5.5	7.5	3.7	5.5
适配 GS 驱动器型号	GS3048Y	GS3050Y	GS3075Y	GS3048Y	GS3050Y	GS3075Y	GS3100Y	GS3050Y	GS3050Y
驱动单元电源 (V)	三相 AC 380~440V 50/60Hz								
额定电流 (A)	6.7	10.2	16.3	8.9	12.6	18.4	22.4	8.6	13
额定频率 (Hz)	33.3	33.3	33.3	50	50	50	50	50	50
额定转矩 (N·m)	21	35	53	14	24	35	48	24	35
30min 功率 (kW)	3.7	5.5	7.5	3.7	5.5	7.5	11	5.5	7.5
30min 电流 (A)	10.6	14.2	20.5	13.8	18	24	32.2	12.7	16.9
30min 转矩 (N·m)	37	53	72	24	35	48	70	35	48
额定转速 (r/min)	1000	1000	1000	1500	1500	1500	1500	1500	1500
恒功率范围 (r/min)	1000~4000	1000~4000	1000~4000	1500~8000	1500~8000	1500~8000	1500~8000	1500~5000	1500~5000
最高转速 (r/min)	7000	7000	7000	10000	10000	10000	10000	7000	7000
转动惯量 (kg·m ²)	0.0168	0.0238	0.0309	0.0116	0.0168	0.0238	0.0309	0.0168	0.0238
重量 (kg)	51	66	77	49	51	66	77	51	66
安装型式	IM B5 或 B35								
冷却风机电源	三相 AC 380~440V 50/60Hz 40W 0.14A								
外形尺寸 (见图)	A	208	208	208	208	208	208	208	208
	B	104	104	104	104	104	104	104	104
	C	160	160	160	160	160	160	160	160
	D	215	215	215	215	215	215	215	215
	E	60	80	80	60	60	80	80	60
	F	414	469	524	364	414	469	524	414
	G	285	340	395	235	285	340	395	285
	H	180h7	180h7	180h7	180h7	180h7	180h7	180h7	180h7
	I	14	14	14	14	14	14	14	14
	J	28h6	38h6	38h6	28h6	28h6	38h6	38h6	28h6
	K	212	212	212	212	212	212	212	212
	L	106	106	106	106	106	106	106	106
	N	180	180	180	180	180	180	180	180
	P	40	40	40	40	40	40	40	40
	Q	210	265	320	160	210	265	320	210
	S	60	80	80	53	60	80	80	60
T	5	5	5	5	5	5	5	5	
Z	12	12	12	12	12	12	12	12	

GSK ZJY 系列主轴伺服电动机

表 1 (续)

规格 项目	ZJY208A-7.5BM	ZJY208A-5.5BL	ZJY208A-7.5BL	ZJY208A-11CM	ZJY208A-11EH	ZJY265A-5.5WL	ZJY265A-7.5WL	ZJY265A-11WL	ZJY265A-7.5AM	ZJY265A-11AM	
额定功率 (kW)	7.5	5.5	7.5	11	11	5.5	7.5	11	7.5	11	
适配 GS 驱动器型号	GS3075Y	GS3050Y	GS3075Y	GS3148Y	GS3100Y	GS3075Y	GS3100Y	GS3148Y	GS3100Y	GS3148Y	
驱动单元电源 (V)	三相 AC 380~440V 50/60Hz										
额定电流 (A)	17	12.9	17.9	28.3	25.2	16.3	21.4	30	21.5	30.9	
额定频率 (Hz)	50	50	50	69	100	25	25	25	33.3	33.3	
额定转矩 (N·m)	48	35	48	52.6	35	70	95.5	140	72	105	
30min 功率 (kW)	11	7.5	11	15	15	7.5	11	15	11	15	
30min 电流 (A)	24.6	16.8	24	37	31.6	20.8	30.1	41	29	40.2	
30min 转矩 (N·m)	70	48	70	71.6	48	95.5	140	191	105	145	
额定转速 (r/min)	1500	1500	1500	2000	3000	750	750	750	1000	1000	
恒功率范围 (r/min)	1500~5000	1500~4500	1500~4500	2000~7000	3000~9000	750~3000	750~3000	750~3000	1000~4000	1000~4000	
最高转速 (r/min)	7000	4500	4500	7000	10000	4500	4500	4500	7000	7000	
转动惯量 (kg·m ²)	0.0309	0.0168	0.0238	0.0309	0.0309	0.0744	0.0826	0.086	0.0413	0.0826	
重量 (kg)	77	52	66	77.8	66	107	125	143	89	125	
安装型式	IM B5 或 B35					IM B3 或 B5					
冷却风机电源	三相 AC 380~440V 50/60Hz 40W 0.14A					三相 AC 380~440V 50/60Hz 70W 0.21A					
外形尺寸 (见图)	A	208	208	208	208	208	265	265	265	265	265
	B	104	104	104	104	104	132	132	132	132	132
	C	160	160	160	160	160	185	185	185	185	185
	D	215	215	215	215	215	265	265	265	265	265
	E	80	80	80	110	80	110	110	110	110	110
	F	524	414	469	524	469	488	533	578	443	533
	G	395	285	340	395	340	347	392	437	302	392
	H	180h7	180h7	180h7	180h7	180h7	230h7	230h7	230h7	230h7	230h7
	I	14	14	14	14	14	14	14	14	14	14
	J	38h6	38h6	38h6	48h6	38h6	48h6	48h6	55h6	48h6	48h6
	K	212	212	212	212	212	256	256	256	256	256
	L	106	106	106	106	106	135	135	135	135	135
	N	180	180	180	180	180	230	230	230	230	230
	P	40	40	40	40	40	40	40	40	40	40
	Q	320	210	265	320	265	270	315	360	225	315
	S	80	80	80	110	80	110	110	110	110	110
T	5	5	5	5	5	5	5	5	5	5	
Z	12	12	12	12	12	15	15	15	15	15	

表 1 (续)

规格 项目	ZJY265A-15AM	ZJY265A-5.5BM	ZJY265A-7.5BM	ZJY265A-11BM	ZJY265A-15BM	ZJY265A-18.5BM	ZJY265A-22BM	ZJY265A-7.5BH	ZJY265A-11BH	ZJY265A-15BH	
额定功率 (kW)	15	5.5	7.5	11	15	18.5	22	7.5	11	15	
适配 GS 驱动器型号	GS3150Y	GS3050Y	GS3075Y	GS3100Y	GS3150Y	GS3150Y	GS3200Y	GS3100Y	GS3148Y	GS3150Y	
驱动单元电源 (V)	三相 AC 380~440V 50/60Hz										
额定电流 (A)	48.3	15	18	26	35	48.7	58	21	30	40.7	
额定频率 (Hz)	33.3	50	50	50	50	50	50	50	50	50	
额定转矩 (N·m)	143	35	49	72	98	118	140	48	70	95	
30min 功率 (kW)	18.5	7.5	11	15	18.5	22	30	11	15	18.5	
30min 电流 (A)	56	18.7	26	34	42	54.7	73	28.5	38.3	42.7	
30min 转矩 (N·m)	177	48	74	100	123	140	191	70	95	118	
额定转速 (r/min)	1000	1500	1500	1500	1500	1500	1500	1500	1500	1500	
恒功率范围 (r/min)	1000~4000	1500~5000	1500~5000	1500~5000	1500~5000	1500~5000	1500~5000	1500~8000	1500~8000	1500~8000	
最高转速 (r/min)	7000	7000	7000	7000	7000	7000	7000	10000	10000	10000	
转动惯量 (kg·m ²)	0.086	0.0205	0.0413	0.0744	0.0826	0.086	0.102	0.0413	0.0744	0.0826	
重量 (kg)	143	62	89	107	125	143	162	89	107	125	
安装型式	IM B3 或 B5										
冷却风机电源	三相 AC 380~440V 50/60Hz 70W 0.21A										
外形尺寸 (见图)	A	265	265	265	265	265	265	265	265	265	265
	B	132	132	132	132	132	132	132	132	132	132
	C	185	185	185	185	185	185	185	185	185	185
	D	265	265	265	265	265	265	265	265	265	265
	E	110	110	110	110	110	110	110	110	110	110
	F	578	383	443	488	533	578	633	443	488	533
	G	437	242	302	347	392	437	492	302	347	392
	H	230h7	230h7	230h7	230h7	230h7	230h7	230h7	230h7	230h7	230h7
	I	14	14	14	14	14	14	14	14	14	14
	J	48h6	48h6	48h6	48h6	48h6	55h6	55h6	48h6	48h6	48h6
	K	256	256	256	256	256	256	256	256	256	256
	L	135	135	135	135	135	135	135	135	135	135
	N	230	230	230	230	230	230	230	230	230	230
	P	40	40	40	40	40	40	40	40	40	40
	Q	360	165	225	270	315	360	415	225	270	315
	S	110	110	110	110	110	110	110	110	110	110
T	5	5	5	5	5	5	5	5	5	5	
Z	15	15	15	15	15	15	15	15	15	15	

4.2 三相 220V 主轴电动机主要技术参数及外形尺寸见表 2。

表 2

规格 项目	ZJY182-1.5BH	ZJY182-2.2BH	ZJY182-2.2CF	ZJY182-3.7BH	ZJY182-3.7DF	ZJY182-5.5CF	ZJY208A-3.7WL	ZJY208A-2.2AM	
额定功率 (kW)	1.5	2.2	2.2	3.7	3.7	5.5	3.7	2.2	
适配 GS 驱动器型号	GS2050Y	GS2050Y	GS2075Y	GS2100Y	GS2100Y	GS2100Y	GS2075Y	GS2050Y	
驱动单元电源 (V)	三相 AC 220V 50/60Hz								
额定电流 (A)	10.7	12.9	14.5	23.5	22.9	32.5	19.6	11.6	
额定频率 (Hz)	50	50	69	50	87	70	25	33.3	
额定转矩 (N·m)	9.5	14	10.5	24	14	26	47	21	
30min 功率 (kW)	2.2	3.7	3.7	5.5	5.5	7.5	5.5	3.7	
30min 电流 (A)	17.6	20	23	36.4	33.8	47.6	27.3	18.4	
30min 转矩 (N·m)	14	24	17.7	35	21	37	70	37	
额定转速 (r/min)	1500	1500	2000	1500	2500	2000	750	1000	
恒功率范围 (r/min)	1500~8000	1500~8000	2000~10000	1500~8000	2500~10000	2000~10000	750~3000	1000~4000	
最高转速 (r/min)	10000	10000	12000	10000	12000	12000	4500	7000	
转动惯量 (kg·m ²)	0.0056	0.0074	0.0056	0.0115	0.0074	0.0115	0.0309	0.0168	
重量 (kg)	27	32	27	43	32	43	77	51	
安装型式	IM B5 或 B35								
冷却风机电源	三相 AC 220V 50/60Hz 37W 0.1A						三相 AC 220V 50/60Hz 40W 0.14A		
外形尺寸 (见图)	A	182	182	182	182	182	182	208	208
	B	91	91	91	91	91	91	104	104
	C	126	126	126	126	126	126	160	160
	D	185	185	185	185	185	185	215	215
	E	60	60	60	60	60	60	80	60
	F	324	351	324	406	351	406	524	414
	G	198	225	198	280	225	280	395	285
	H	150h7	150h7	150h7	150h7	150h7	150h7	180h7	180h7
	I	12	12	12	12	12	12	14	14
	J	28h6	28h6	28h6	28h6	28h6	28h6	38h6	28h6
	K	184	184	184	184	184	184	212	212
	L	93	93	93	93	93	93	106	106
	N	156	156	156	156	156	156	180	180
	P	32	32	32	32	32	32	40	40
Q	132	159	132	214	159	214	320	210	
S	60	60	60	60	60	60	80	60	
T	4	4	4	4	4	4	5	5	
Z	12	12	12	12	12	12	12	12	

表 2 (续)

规格 项目	ZJY208A-3.7AM	ZJY208A-5.5AM	ZJY208A-2.2BH	ZJY208A-3.7BH	ZJY208A-5.5BH	ZJY208A-3.7BM	ZJY208A-5.5BM	ZJY208A-7.5BM
额定功率 (kW)	3.7	5.5	2.2	3.7	5.5	3.7	5.5	7.5
适配 GS 驱动器型号	GS2075Y	GS2100Y	GS2075Y	GS2100Y	GS2100Y	GS2075Y	GS2100Y	GS2100Y
驱动单元电源 (V)	三相 AC 220V 50/60Hz							
额定电流 (A)	17.7	28.2	15.3	21.8	31.8	14.9	22.5	29.4
额定频率 (Hz)	33.3	33.3	50	50	50	50	50	50
额定转矩 (N·m)	35	53	14	24	35	24	35	48
30min 功率 (kW)	5.5	7.5	3.7	5.5	7.5	5.5	7.5	11
30min 电流 (A)	24.6	35.5	23.9	31.2	41.6	22	29.3	42.6
30min 转矩 (N·m)	53	72	24	35	48	35	48	70
额定转速 (r/min)	1000	1000	1500	1500	1500	1500	1500	1500
恒功率范围 (r/min)	1000~4000	1000~4000	1500~8000	1500~8000	1500~8000	1500~5000	1500~5000	1500~5000
最高转速 (r/min)	7000	7000	10000	10000	10000	7000	7000	7000
转动惯量 (kg·m ²)	0.0238	0.0309	0.0116	0.0168	0.0238	0.0168	0.0238	0.0309
重量 (kg)	66	77	49	51	66	51	66	77
安装型式	IM B5 或 B35							
冷却风机电源	三相 AC 220V 50/60Hz 40W 0.14A							
外形尺寸 (见图)	A	208	208	208	208	208	208	208
	B	104	104	104	104	104	104	104
	C	160	160	160	160	160	160	160
	D	215	215	215	215	215	215	215
	E	80	80	60	60	80	60	80
	F	469	524	364	414	469	414	469
	G	340	395	235	285	340	285	340
	H	180h7	180h7	180h7	180h7	180h7	180h7	180h7
	I	14	14	14	14	14	14	14
	J	38h6	38h6	28h6	28h6	38h6	28h6	38h6
	K	212	212	212	212	212	212	212
	L	106	106	106	106	106	106	106
	N	180	180	180	180	180	180	180
	P	40	40	40	40	40	40	40
	Q	265	320	160	210	265	210	265
	S	80	80	53	60	80	60	80
T	5	5	5	5	5	5	5	
Z	12	12	12	12	12	12	12	

4.3 电动机的各安装型式外形图

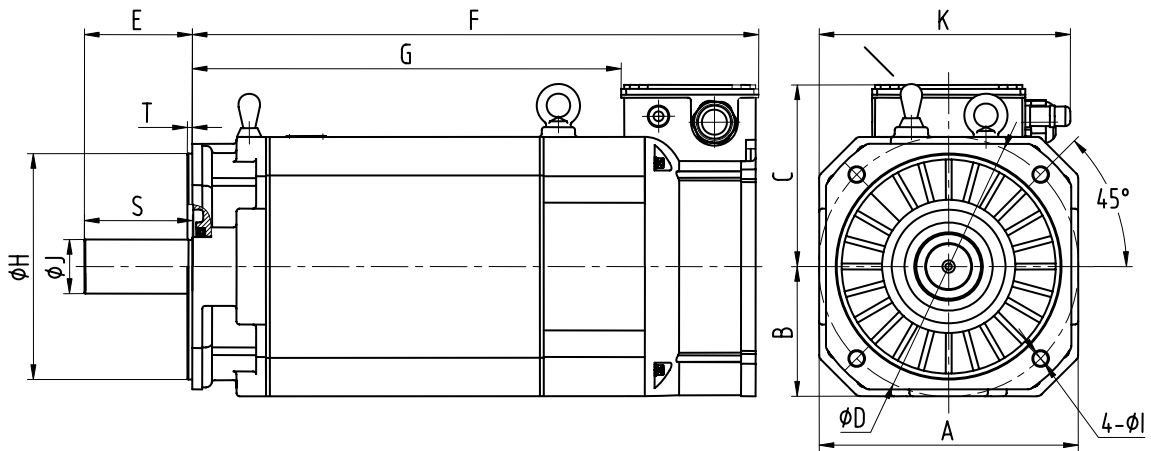

凸缘安装型式 (B5)

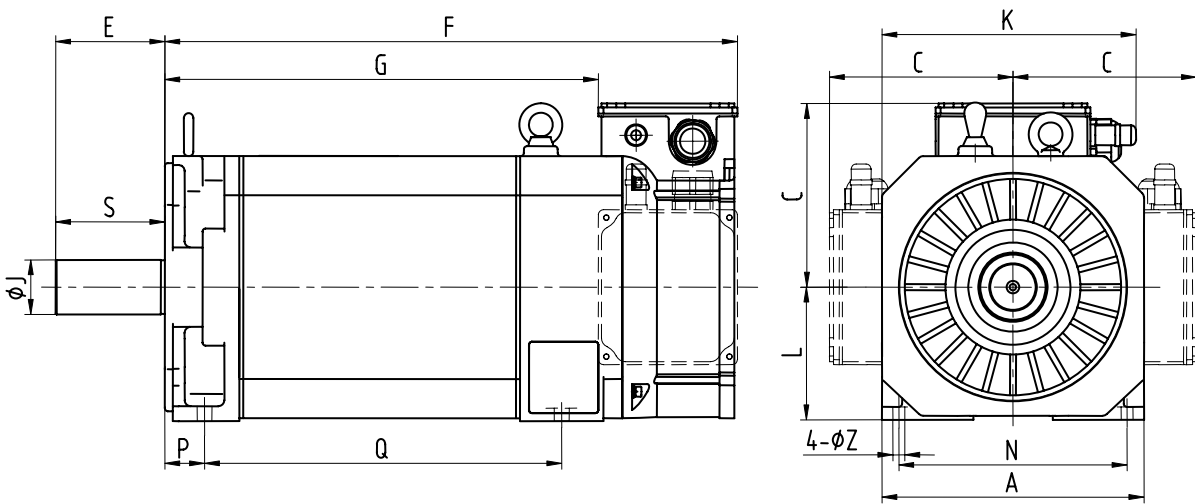

底脚安装型式 (B3) 及左右出线方式

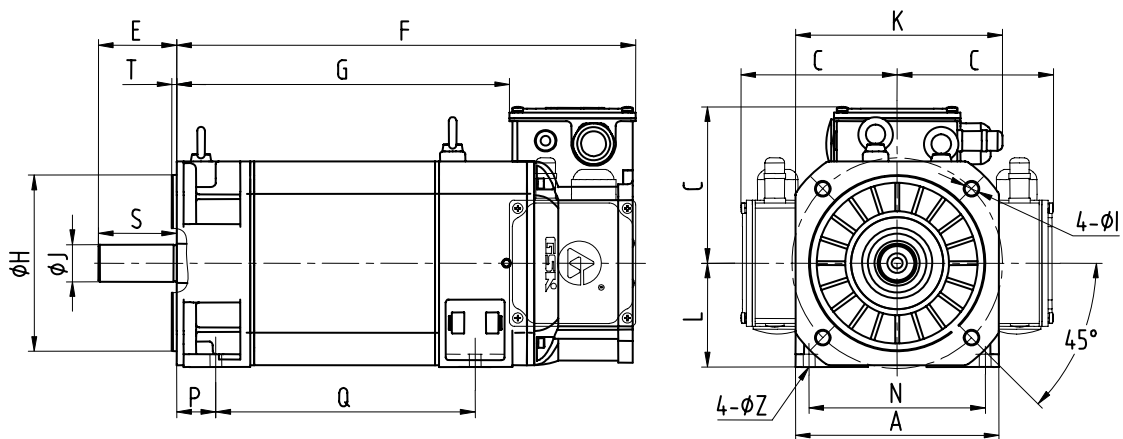

凸缘底脚安装型式 (B35) 及左右出线方式

4.4 标准键槽尺寸

4.4.1 ZJY182-3.7BM、ZJY208A-3.7BM、ZJY208A-2.2AM

所配键：GB/T 1096 键 8×7×50

轴伸键槽尺寸见下左图，转轴端面中心螺孔 M10×20

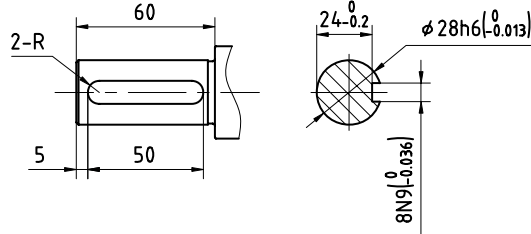

4.4.2 ZJY208A-5.5BM 、 ZJY208A-7.5BM 、 ZJY208A-5.5BL 、 ZJY208A-7.5BL 、 ZJY208A-3.7AM、ZJY208A-3.7WL、ZJY208A-5.5AM

所配键：GB/T 1096 键 10×8×70

轴伸键槽尺寸见下图，转轴端面中心螺孔 M10×20

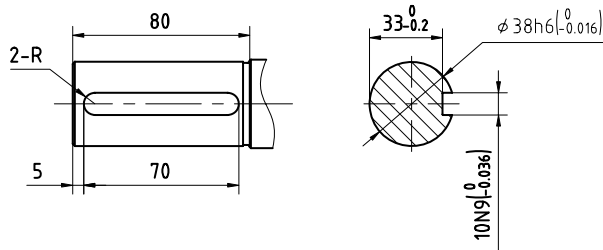

4.4.3 ZJY265A-5.5WL 、 ZJY265A-7.5WL 、 ZJY265A-5.5BM 、 ZJY265A-7.5BM 、 ZJY265A-11BM 、 ZJY265A-15BM 、 ZJY265A-7.5AM 、 ZJY265A-11AM 、 ZJY265A-15AM、 ZJY208A-11CM

所配键：GB/T 1096 键 14×9×90

轴伸键槽尺寸见下图，转轴端面中心螺孔 M10×20

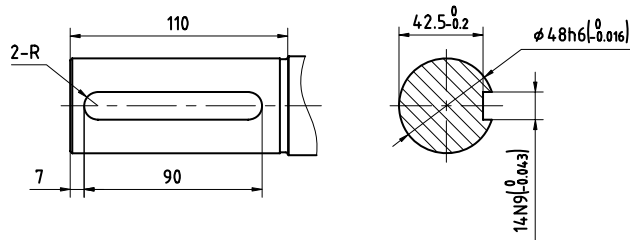

4.4.4 ZJY265A-11WL、ZJY265A-18.5BM、ZJY265A-22BM

所配键：GB/T 1096 键 16×10×90

轴伸键槽尺寸见下图，转轴端面中心螺孔 M10×20

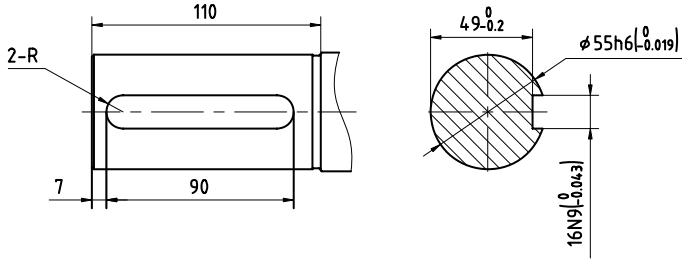

五 电动机机械特性曲线

图例:

- 连续工作状态的功率或转矩;
- - - - 30 分钟工作状态的功率或转矩。

电机型号	功率曲线	转矩曲线
ZJY182-1.5BH		
ZJY182-2.2BH		
ZJY182-2.2CF		

电机型号	功率曲线	转矩曲线
ZJY182-3.7BH		
ZJY182-3.7DF		
ZJY182-5.5CF		
ZJY182-7.5EH		

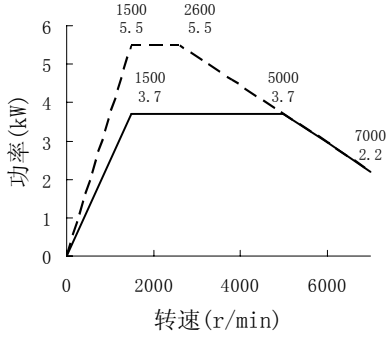
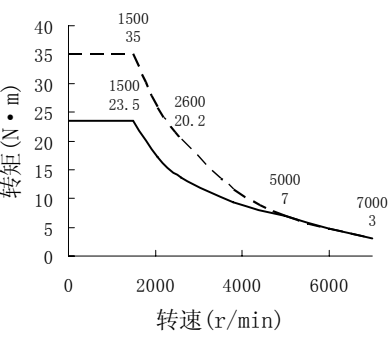
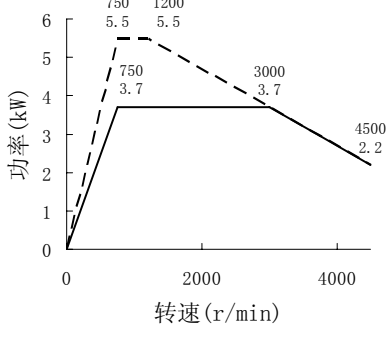
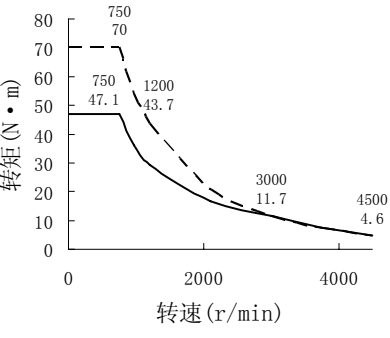
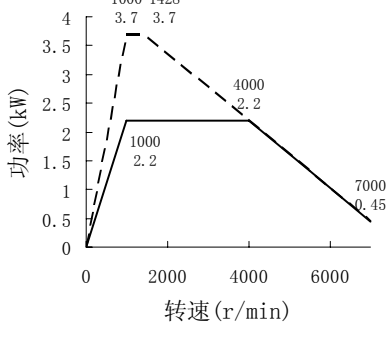
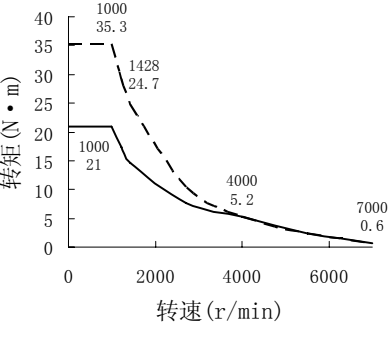
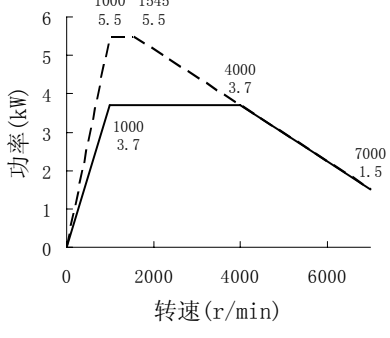
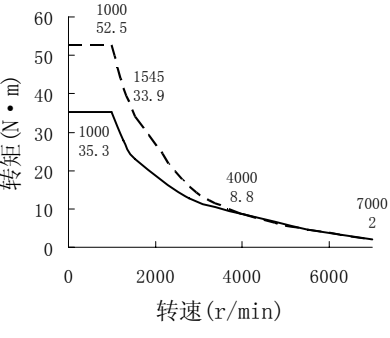
电机型号	功率曲线	转矩曲线
ZJY182-3.7BM	 <p>功率(kW) vs 转速(r/min) for ZJY182-3.7BM. The graph shows two curves: a dashed line for maximum power and a solid line for rated power. Key data points are: (1500, 5.5), (2600, 5.5), (1500, 3.7), (5000, 3.7), and (7000, 2.2).</p>	 <p>转矩(N·m) vs 转速(r/min) for ZJY182-3.7BM. The graph shows two curves: a dashed line for maximum torque and a solid line for rated torque. Key data points are: (1500, 35), (2600, 20.2), (1500, 23.5), (5000, 7), and (7000, 3).</p>
ZJY208A-3.7WL	 <p>功率(kW) vs 转速(r/min) for ZJY208A-3.7WL. The graph shows two curves: a dashed line for maximum power and a solid line for rated power. Key data points are: (750, 5.5), (1200, 5.5), (750, 3.7), (3000, 3.7), and (4500, 2.2).</p>	 <p>转矩(N·m) vs 转速(r/min) for ZJY208A-3.7WL. The graph shows two curves: a dashed line for maximum torque and a solid line for rated torque. Key data points are: (750, 70), (1200, 43.7), (750, 47.1), (3000, 11.7), and (4500, 4.6).</p>
ZJY208A-2.2AM	 <p>功率(kW) vs 转速(r/min) for ZJY208A-2.2AM. The graph shows two curves: a dashed line for maximum power and a solid line for rated power. Key data points are: (1000, 3.7), (1428, 3.7), (1000, 2.2), (4000, 2.2), and (7000, 0.45).</p>	 <p>转矩(N·m) vs 转速(r/min) for ZJY208A-2.2AM. The graph shows two curves: a dashed line for maximum torque and a solid line for rated torque. Key data points are: (1000, 35.3), (1428, 24.7), (1000, 21), (4000, 5.2), and (7000, 0.6).</p>
ZJY208A-3.7AM	 <p>功率(kW) vs 转速(r/min) for ZJY208A-3.7AM. The graph shows two curves: a dashed line for maximum power and a solid line for rated power. Key data points are: (1000, 5.5), (1545, 5.5), (1000, 3.7), (4000, 3.7), and (7000, 1.5).</p>	 <p>转矩(N·m) vs 转速(r/min) for ZJY208A-3.7AM. The graph shows two curves: a dashed line for maximum torque and a solid line for rated torque. Key data points are: (1000, 52.5), (1545, 33.9), (1000, 35.3), (4000, 8.8), and (7000, 2).</p>

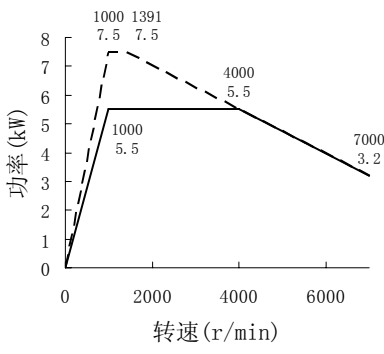
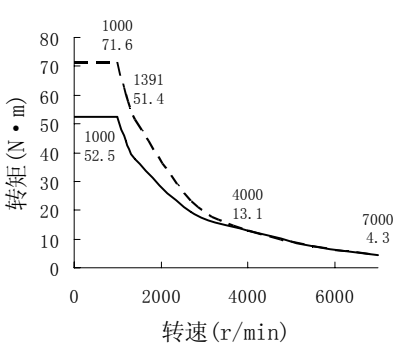
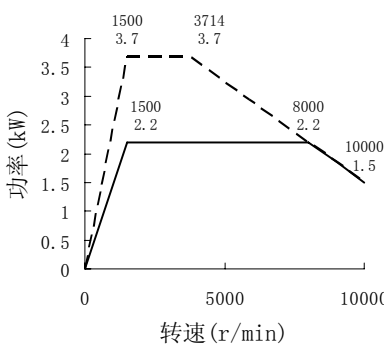
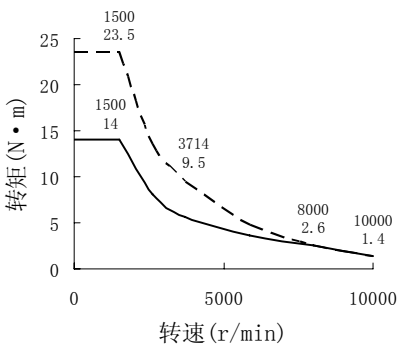
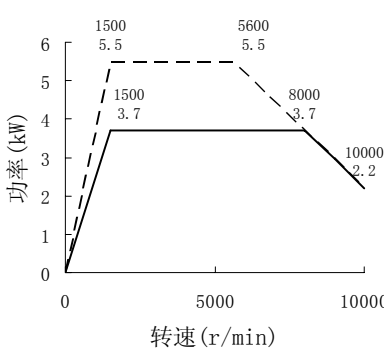
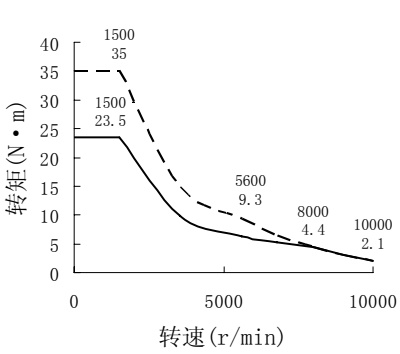
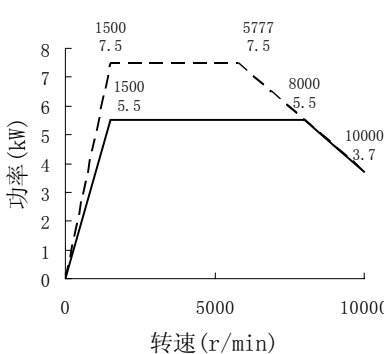
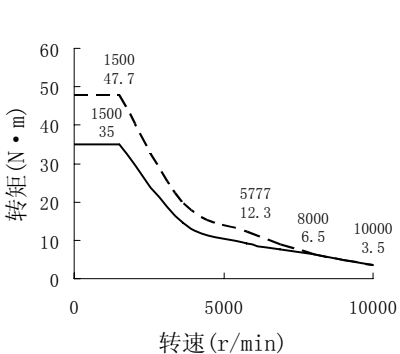
电机型号	功率曲线	转矩曲线
ZJY208A-5.5AM	 <p>功率(kW) vs 转速(r/min) for ZJY208A-5.5AM. The graph shows two curves: a solid line for rated power and a dashed line for maximum power. Key data points are: (1000, 5.5), (1391, 7.5), (4000, 5.5), and (7000, 3.2).</p>	 <p>转矩(N·m) vs 转速(r/min) for ZJY208A-5.5AM. The graph shows two curves: a solid line for rated torque and a dashed line for maximum torque. Key data points are: (1000, 52.5), (1391, 71.6), (4000, 13.1), and (7000, 4.3).</p>
ZJY208A-2.2BH	 <p>功率(kW) vs 转速(r/min) for ZJY208A-2.2BH. The graph shows two curves: a solid line for rated power and a dashed line for maximum power. Key data points are: (1500, 2.2), (3714, 3.7), (8000, 2.2), and (10000, 1.5).</p>	 <p>转矩(N·m) vs 转速(r/min) for ZJY208A-2.2BH. The graph shows two curves: a solid line for rated torque and a dashed line for maximum torque. Key data points are: (1500, 14), (3714, 23.5), (8000, 2.6), and (10000, 1.4).</p>
ZJY208A-3.7BH	 <p>功率(kW) vs 转速(r/min) for ZJY208A-3.7BH. The graph shows two curves: a solid line for rated power and a dashed line for maximum power. Key data points are: (1500, 3.7), (5600, 5.5), (8000, 3.7), and (10000, 2.2).</p>	 <p>转矩(N·m) vs 转速(r/min) for ZJY208A-3.7BH. The graph shows two curves: a solid line for rated torque and a dashed line for maximum torque. Key data points are: (1500, 23.5), (5600, 35), (8000, 4.4), and (10000, 2.1).</p>
ZJY208A-5.5BH	 <p>功率(kW) vs 转速(r/min) for ZJY208A-5.5BH. The graph shows two curves: a solid line for rated power and a dashed line for maximum power. Key data points are: (1500, 5.5), (5777, 7.5), (8000, 5.5), and (10000, 3.7).</p>	 <p>转矩(N·m) vs 转速(r/min) for ZJY208A-5.5BH. The graph shows two curves: a solid line for rated torque and a dashed line for maximum torque. Key data points are: (1500, 35), (5777, 47.7), (8000, 6.5), and (10000, 3.5).</p>

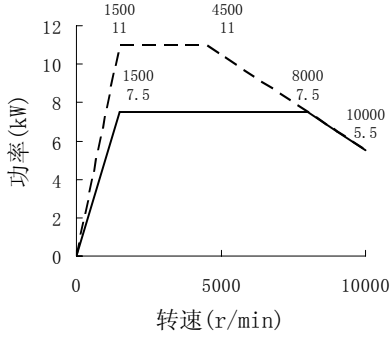
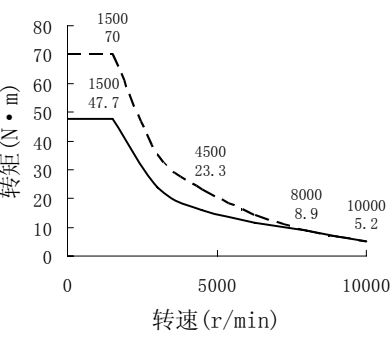
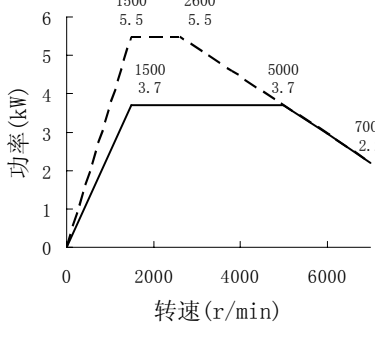
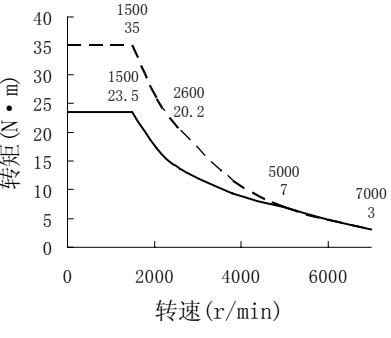
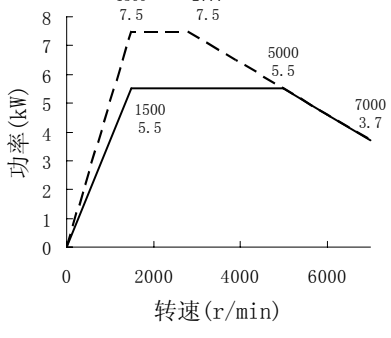
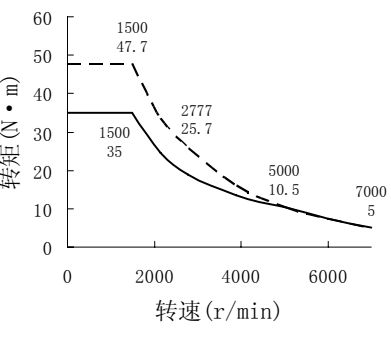
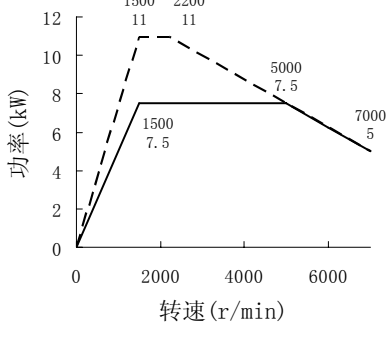
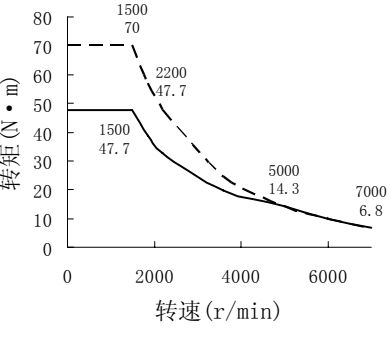
电机型号	功率曲线	转矩曲线
ZJY208A-7.5BH	 <p>功率(kW) vs 转速(r/min) for ZJY208A-7.5BH. The graph shows two curves: a solid line for rated power and a dashed line for maximum power. Key data points are: (1500, 7.5) and (1500, 11) for the solid line; (4500, 11) for the dashed line; (8000, 7.5) and (10000, 5.5) for the solid line.</p>	 <p>转矩(N·m) vs 转速(r/min) for ZJY208A-7.5BH. The graph shows two curves: a solid line for rated torque and a dashed line for maximum torque. Key data points are: (1500, 47.7) and (1500, 70) for the solid line; (4500, 23.3) for the dashed line; (8000, 8.9) and (10000, 5.2) for the solid line.</p>
ZJY208A-3.7BM	 <p>功率(kW) vs 转速(r/min) for ZJY208A-3.7BM. The graph shows two curves: a solid line for rated power and a dashed line for maximum power. Key data points are: (1500, 3.7) and (1500, 5.5) for the solid line; (2600, 5.5) for the dashed line; (5000, 3.7) and (7000, 2.2) for the solid line.</p>	 <p>转矩(N·m) vs 转速(r/min) for ZJY208A-3.7BM. The graph shows two curves: a solid line for rated torque and a dashed line for maximum torque. Key data points are: (1500, 23.5) and (1500, 35) for the solid line; (2600, 20.2) for the dashed line; (5000, 7) and (7000, 3) for the solid line.</p>
ZJY208A-5.5BM	 <p>功率(kW) vs 转速(r/min) for ZJY208A-5.5BM. The graph shows two curves: a solid line for rated power and a dashed line for maximum power. Key data points are: (1500, 5.5) and (1500, 7.5) for the solid line; (2777, 7.5) for the dashed line; (5000, 5.5) and (7000, 3.7) for the solid line.</p>	 <p>转矩(N·m) vs 转速(r/min) for ZJY208A-5.5BM. The graph shows two curves: a solid line for rated torque and a dashed line for maximum torque. Key data points are: (1500, 35) and (1500, 47.7) for the solid line; (2777, 25.7) for the dashed line; (5000, 10.5) and (7000, 5) for the solid line.</p>
ZJY208A-7.5BM	 <p>功率(kW) vs 转速(r/min) for ZJY208A-7.5BM. The graph shows two curves: a solid line for rated power and a dashed line for maximum power. Key data points are: (1500, 7.5) and (1500, 11) for the solid line; (2200, 11) for the dashed line; (5000, 7.5) and (7000, 5) for the solid line.</p>	 <p>转矩(N·m) vs 转速(r/min) for ZJY208A-7.5BM. The graph shows two curves: a solid line for rated torque and a dashed line for maximum torque. Key data points are: (1500, 47.7) and (1500, 70) for the solid line; (2200, 47.7) for the dashed line; (5000, 14.3) and (7000, 6.8) for the solid line.</p>

电机型号	功率曲线	转矩曲线
ZJY208A-5.5BL	<p>功率(kW)</p> <p>转速(r/min)</p> <p>1500 7.5</p> <p>1500 5.5</p> <p>4500 5.5</p>	<p>转矩(N·m)</p> <p>转速(r/min)</p> <p>1500 47.7</p> <p>1500 35</p> <p>4500 11.6</p>
ZJY208A-7.5BL	<p>功率(kW)</p> <p>转速(r/min)</p> <p>1500 11</p> <p>1500 7.5</p> <p>4500 7.5</p>	<p>转矩(N·m)</p> <p>转速(r/min)</p> <p>1500 70</p> <p>1500 47.7</p> <p>4500 15.9</p>
ZJY208A-11CM	<p>功率(kW)</p> <p>转速(r/min)</p> <p>2000 15</p> <p>2000 11</p> <p>7000 11</p>	<p>转矩(N·m)</p> <p>转速(r/min)</p> <p>2000 71.6</p> <p>2000 52.5</p> <p>7000 15</p>
ZJY208A-11EH	<p>功率(kW)</p> <p>转速(r/min)</p> <p>3000 15</p> <p>3000 11</p> <p>9000 11</p> <p>10000 7.5</p>	<p>转矩(N·m)</p> <p>转速(r/min)</p> <p>3000 47.7</p> <p>3000 35</p> <p>7857 18.2</p> <p>9000 11.6</p> <p>10000 7.1</p>

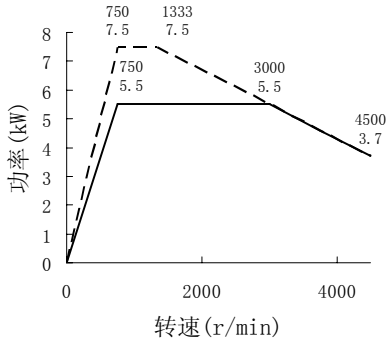
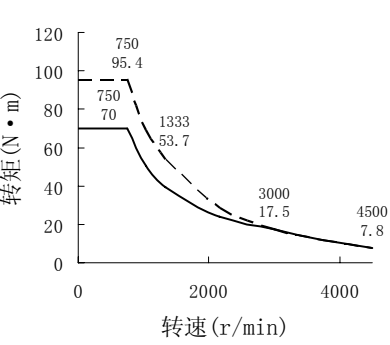
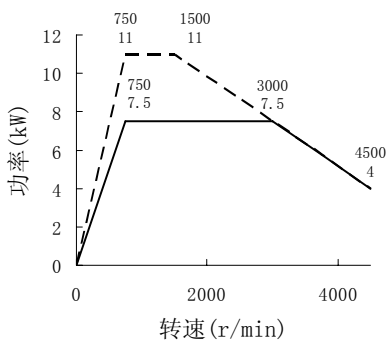
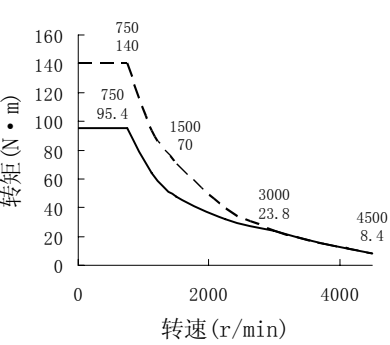
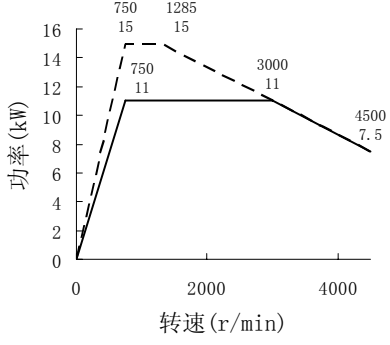
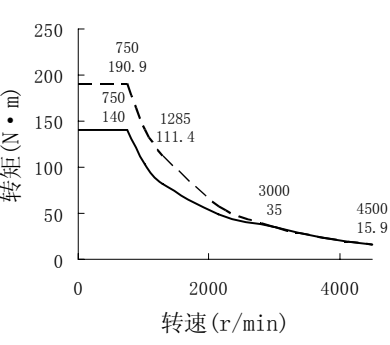
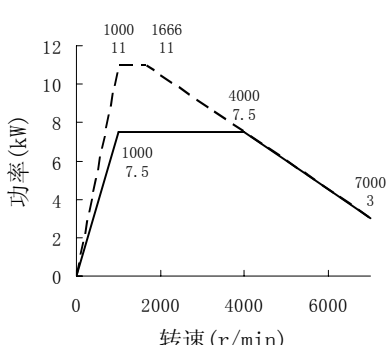
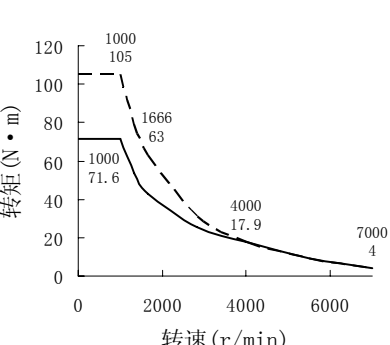
电机型号	功率曲线	转矩曲线
ZJY265A-5.5WL	 <p>功率(kW) vs 转速(r/min) for ZJY265A-5.5WL. The graph shows a dashed line for peak power and a solid line for rated power. Key points: (750, 7.5), (1333, 7.5), (750, 5.5), (3000, 5.5), (4500, 3.7).</p>	 <p>转矩(N·m) vs 转速(r/min) for ZJY265A-5.5WL. The graph shows a dashed line for peak torque and a solid line for rated torque. Key points: (750, 95.4), (750, 70), (1333, 53.7), (3000, 17.5), (4500, 7.8).</p>
ZJY265A-7.5WL	 <p>功率(kW) vs 转速(r/min) for ZJY265A-7.5WL. The graph shows a dashed line for peak power and a solid line for rated power. Key points: (750, 11), (1500, 11), (750, 7.5), (3000, 7.5), (4500, 4).</p>	 <p>转矩(N·m) vs 转速(r/min) for ZJY265A-7.5WL. The graph shows a dashed line for peak torque and a solid line for rated torque. Key points: (750, 140), (750, 95.4), (1500, 70), (3000, 23.8), (4500, 8.4).</p>
ZJY265A-11WL	 <p>功率(kW) vs 转速(r/min) for ZJY265A-11WL. The graph shows a dashed line for peak power and a solid line for rated power. Key points: (750, 15), (1285, 15), (750, 11), (3000, 11), (4500, 7.5).</p>	 <p>转矩(N·m) vs 转速(r/min) for ZJY265A-11WL. The graph shows a dashed line for peak torque and a solid line for rated torque. Key points: (750, 190.9), (750, 140), (1285, 111.4), (3000, 35), (4500, 15.9).</p>
ZJY265A-7.5AM	 <p>功率(kW) vs 转速(r/min) for ZJY265A-7.5AM. The graph shows a dashed line for peak power and a solid line for rated power. Key points: (1000, 11), (1666, 11), (1000, 7.5), (4000, 7.5), (7000, 3).</p>	 <p>转矩(N·m) vs 转速(r/min) for ZJY265A-7.5AM. The graph shows a dashed line for peak torque and a solid line for rated torque. Key points: (1000, 105), (1666, 63), (1000, 71.6), (4000, 17.9), (7000, 4).</p>

电机型号	功率曲线	转矩曲线
ZJY265A-11AM	<p>功率 (kW)</p> <p>转速 (r/min)</p>	<p>转矩 (N·m)</p> <p>转速 (r/min)</p>
ZJY265A-15AM	<p>功率 (kW)</p> <p>转速 (r/min)</p>	<p>转矩 (N·m)</p> <p>转速 (r/min)</p>
ZJY265A-5.5BM	<p>功率 (kW)</p> <p>转速 (r/min)</p>	<p>转矩 (N·m)</p> <p>转速 (r/min)</p>
ZJY265A-7.5BM	<p>功率 (kW)</p> <p>转速 (r/min)</p>	<p>转矩 (N·m)</p> <p>转速 (r/min)</p>

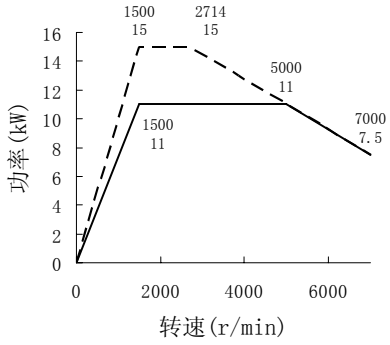
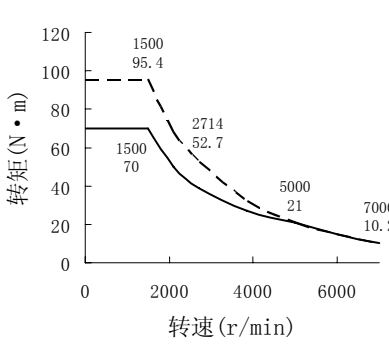
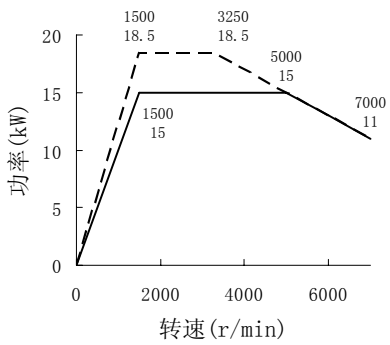
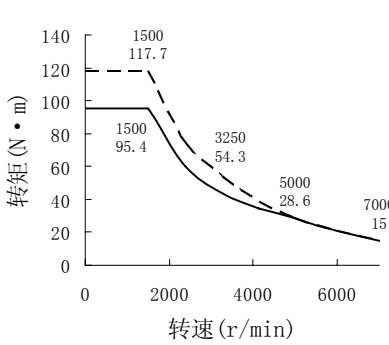
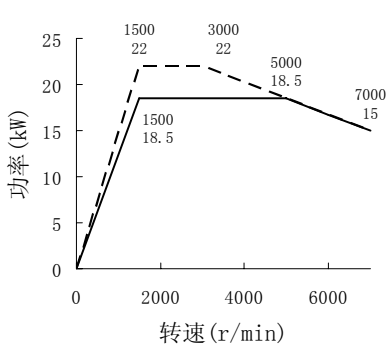
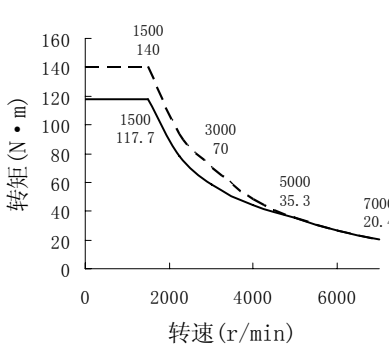
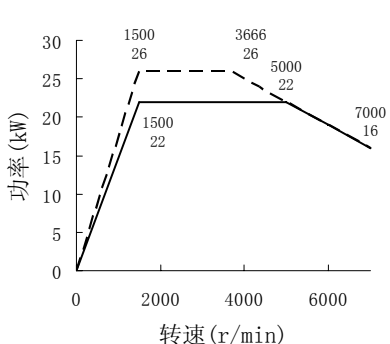
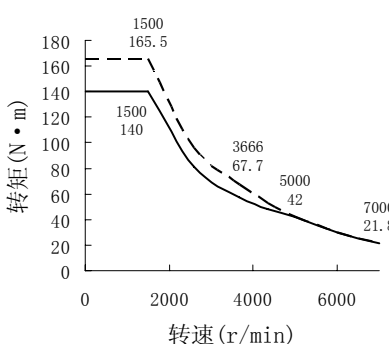
电机型号	功率曲线	转矩曲线
ZJY265A-11BM	 <p>功率(kW) vs 转速(r/min) for ZJY265A-11BM. The graph shows two curves: a solid line for rated power and a dashed line for maximum power. Key data points are: (1500, 11) and (1500, 15) for the solid line; (2714, 15) and (5000, 11) for the dashed line; and (7000, 7.5) for the solid line at 7000 rpm.</p>	 <p>转矩(N·m) vs 转速(r/min) for ZJY265A-11BM. Key data points: (1500, 70) and (1500, 95.4) for the solid line; (2714, 52.7) and (5000, 21) for the dashed line; and (7000, 10.2) for the solid line at 7000 rpm.</p>
ZJY265A-15BM	 <p>功率(kW) vs 转速(r/min) for ZJY265A-15BM. Key data points: (1500, 15) and (1500, 18.5) for the solid line; (3250, 18.5) and (5000, 15) for the dashed line; and (7000, 11) for the solid line at 7000 rpm.</p>	 <p>转矩(N·m) vs 转速(r/min) for ZJY265A-15BM. Key data points: (1500, 95.4) and (1500, 117.7) for the solid line; (3250, 54.3) and (5000, 28.6) for the dashed line; and (7000, 15) for the solid line at 7000 rpm.</p>
ZJY265A-18.5BM	 <p>功率(kW) vs 转速(r/min) for ZJY265A-18.5BM. Key data points: (1500, 18.5) and (1500, 22) for the solid line; (3000, 22) and (5000, 18.5) for the dashed line; and (7000, 15) for the solid line at 7000 rpm.</p>	 <p>转矩(N·m) vs 转速(r/min) for ZJY265A-18.5BM. Key data points: (1500, 117.7) and (1500, 140) for the solid line; (3000, 70) and (5000, 35.3) for the dashed line; and (7000, 20.4) for the solid line at 7000 rpm.</p>
ZJY265A-22BM	 <p>功率(kW) vs 转速(r/min) for ZJY265A-22BM. Key data points: (1500, 22) and (1500, 26) for the solid line; (3666, 26) and (5000, 22) for the dashed line; and (7000, 16) for the solid line at 7000 rpm.</p>	 <p>转矩(N·m) vs 转速(r/min) for ZJY265A-22BM. Key data points: (1500, 140) and (1500, 165.5) for the solid line; (3666, 67.7) and (5000, 42) for the dashed line; and (7000, 21.8) for the solid line at 7000 rpm.</p>

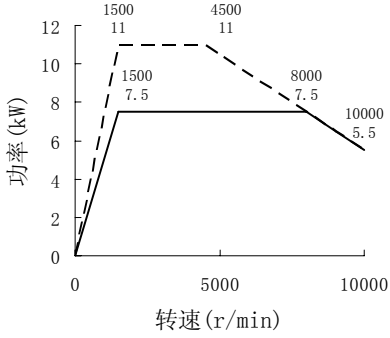
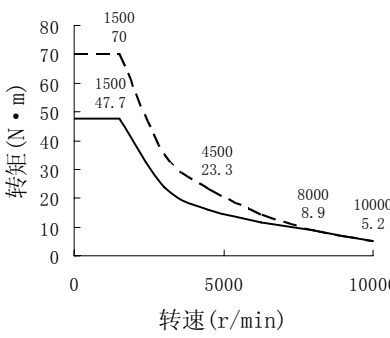
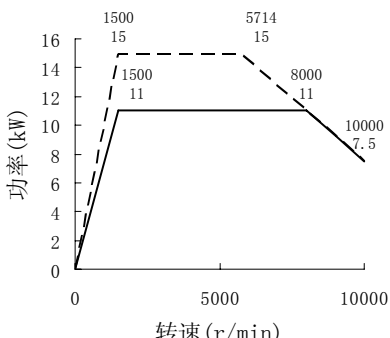
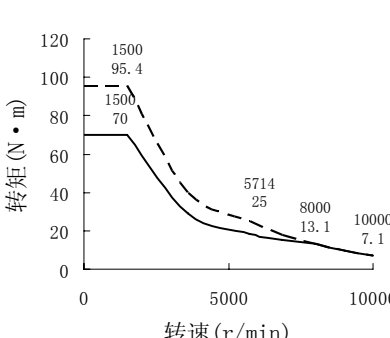
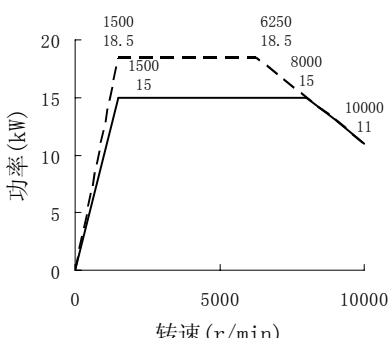
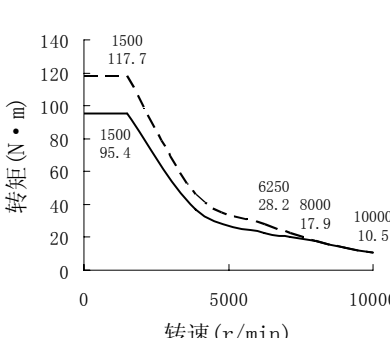
电机型号	功率曲线	转矩曲线
ZJY265A-7.5BH		
ZJY265A-11BH		
ZJY265A-15BH		

六 电动机的连接及安装

6.1 电动机与驱动单元的连接

6.1.1 电动机的三相绕组 U、V、W 和机壳（地）通过电缆固定头引出，其在接线盒内的位置关系见下图。U、V、W、机壳（地）分别接驱动单元的主回路 U、V、W、PE 端子。冷却风机风向为从轴伸端吹向尾端。

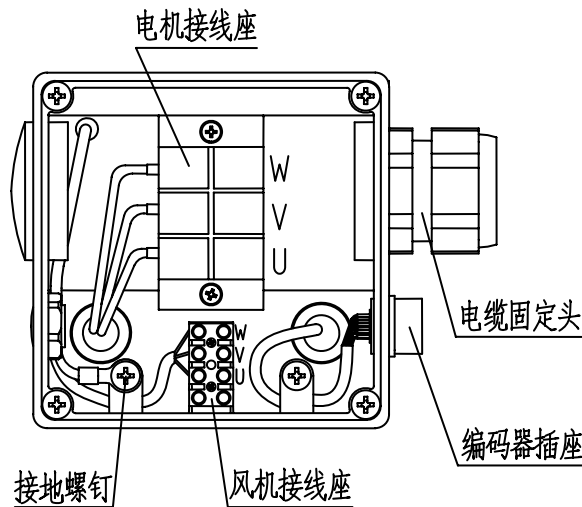

ZJY208A、ZJY265A 接线盒

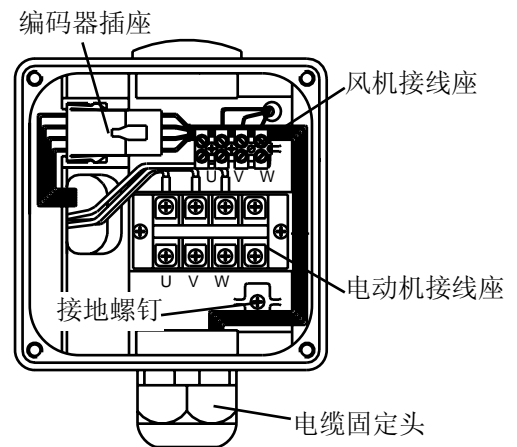

ZJY182 接线盒

6.1.2 编码器接口

6.1.2.1 ZJY182 系列电机的增量式编码器引线通过接线盒内的 12 芯接插件插头引出，其对应关系见表 3。引出线按驱动单元要求连接到驱动单元反馈信号 CN2 的插头上。

表 3

编码器引线	机壳（地）	V _{CC}	GND	A	\bar{A}	B	\bar{B}	Z	\bar{Z}
插座编号	1	9	5	6	10	7	11	8	12

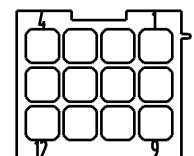

插头（背面）
示意

6.1.2.2 ZJY208A、ZJY265A 系列电机的增量式编码器引线通过一个 12 芯圆形连接器插座引出，其对应关系见表 4。引出线按驱动单元要求连接到驱动单元反馈信号 CN2 的插头上。

表 4

编码器引线	机壳(地)	V _{CC}	GND	A	\bar{A}	B	\bar{B}	Z	\bar{Z}
插座编号	0	1	2	3	6	4	7	5	8

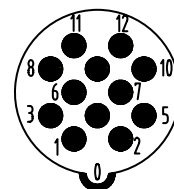

圆形连接器插座(焊线侧)示意

6.2 电动机的安装

电动机需要运行在 2000r/min 以上转速时，推荐选用光轴的电机，使用胀紧套方式固定皮带轮，并且皮带轮及胀紧套必须是经过动平衡工艺并达到 G1 要求，否则高速运行时会产生较大的振动。

6.2.1 B5 凸缘安装方式（或使用 B35 的凸缘安装方式）

ZJY182 系列使用 M10×35 的螺栓或内六角螺钉，使用内六角螺钉时，可自制一根长度大于电机总长的内六角扳手，取下风机罩上的橡胶塞，从后端紧固螺钉，紧固后塞回橡胶塞。（见图 4）

ZJY208A、ZJY265A 系列使用 M12×45 的螺栓或内六角螺钉安装。

6.2.2 B3 底脚安装方式（或使用 B35 的底脚安装方式）

安装时先卸下后端盖两侧边的封板，B35 结构的还要取下底脚孔上的橡胶塞（见图 5），

ZJY182 和 ZJY208A 使用 M10×30 的内六角螺钉安装，ZJY265A 使用 M12×40 的内六角螺钉安装。



图 4



图 5

电动机固定好以后，后端盖两侧边的封板必须安装，不然会因为漏风影响冷却效果，造成电动机过热损坏。

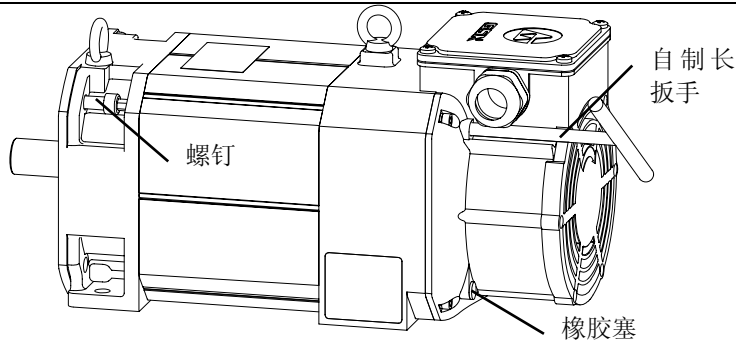
七 电动机的贮存

电动机应存放在环境温度为 $-40^{\circ}\text{C} \sim +70^{\circ}\text{C}$ 、相对湿度不大于 95% 的清洁通风良好的库房内，空气中不得含有腐蚀性气体。

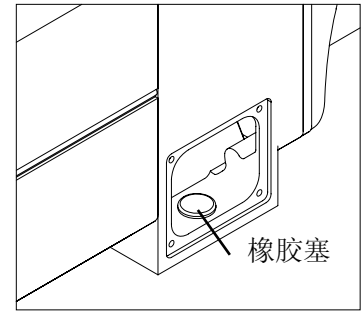
八 电动机的运输

运输过程中应小心轻放，避免碰撞和冲击，严禁与酸、碱等腐蚀性物质放在一起。

九 质量保证期

用户在符合产品运输、储存、安装、调试、维修及遵守使用规程的条件下，自本公司发货之日起（按发货凭证为据）壹年内，凡电动机因制造质量不良而发生损坏或不能正常使用时，本公司负责免费修理。

注 1： 以上电动机为本公司推荐规格，可适应多数应用场合，如果用户有新的要求，本公司可提供其他规格的电动机。

注 2： 本公司生产的电动机的基本轴伸为圆柱不带键槽型式。本公司可根据用户的需要提供其他不同轴伸型式的电动机（订货时需特别注明），圆柱形带键槽轴（可参看 GB/T 756—2010）。

注 3： 因主轴电动机工作转速较高，对旋转部件有相应的动平衡要求，否则会产生较大的振动噪声，甚至损坏电机及设备。主轴电机的转子出厂时动平衡精度为 6000r/min 时达到 G 0.4，用户使用时注意以下几点.:

- ◇ 建议选用轴伸为光轴的主轴电机
- ◇ 皮带轮必须进行动平衡工艺，要求为 6000 r/min 时达到 G1 或更高精度（约单边剩余不平衡量小于 50 mg），且固定螺钉重量一致，压圈安装后与轴的同轴度不大于 0.1 mm

- ◇ 如果用户因为某些原因而使用键连接方式时，必须根据主轴电机轴伸及键的尺寸和材料制作动平衡芯轴，给皮带轮作动平衡，动平衡精度要求同上。安装皮带轮时可利用电机轴伸端部的螺孔，用螺杆压装，也可以采用热套方式，不允许敲打

- ◇ 对于暂时没有相应动平衡设备的用户，可以短期内委托本公司进行皮带轮动平衡工艺和安装

 In this manual, we have tried as much as possible to describe all the various matters about the spindle servo motor. However, we can not describe all the matters which must not be done or which can not be done because there are so many possibilities. Therefore, matters which are not especially described in this manual should be regarded as “impossible” or “forbidden”.

 The copyright of the user manual is owned by GSK CNC Equipment Co., Ltd (Hereinafter referred to as GSK).It is against the law for any organization or individual to reproduce this manual in any form without the permission of GSK and GSK reserves the right to investigate its law duty.

PREFACE

Dear user:

It's our honor that you select **GSK ZJY** serial spindle servo motor (Hereinafter referred to as the motor).

For safety of the motor and the product and for the normal and effective running, please read the manual carefully before installing and using the product.

SAFETY PRECAUTION



The incorrect connection and operation may cause the accident, so before using and operating the motor, please read the manual carefully!

1. The motor is installed with the photoelectric encoder, and it's not allowed to hit the motor. And the user can't disassemble the photoelectric encoder by himself; otherwise, once the encoder is damaged, it may cause the motor out of running!
2. In the normal climate, measure the insulation resistance, which the motor winding is against with the case, by 1000V megameter, and the value should NOT be less than 20MΩ.
3. The motor and the drive should be connected correctly based on the manual to guarantee the protective grounding stable and reliable.
4. The motor can run with load only after the motor is free of noise and vibration during running from zero speed to the maximum speed in the dry run mode.
5. During the motor running, it's not allowed to touch the motor shaft and case.
6. Only the qualified person can adjust and maintain the motor.
7. It is forbidden to move the motor by dragging the wire (cable), the motor shaft or the encoder.
8. GSK does NOT take any responsibility for any change on the product by the user, and the warranty bill becomes invalid.

All specifications and designs are subject to change without notice.

RESPONSIBILITY

Responsibility of the manufacturer

—The manufacturer should be in charge of the design and the structure of the motor and its accessories.

—The manufacturer should be responsible for the safety of the motor and its accessories.

—The manufacturer should be in charge of the provided information and suggestion for the user.

Responsibility of the end user

—The user should be very familiar with the safety operation through learning the motor safety operation or participating in the training session.

—The user should be responsible for the safety after adding, changing or modifying the original motor and its accessories by himself.

—The user should be in charge of the danger resulted from the operation, adjusting, maintenance, installation and storage which are not complied with the manual regulation.

The manual is kept by **the end user**.

Thank you for your corporation during using GSK product.

Content

I	PRODUCT CHARACTERISTICS	1
II	RUNNING CONDITIONS	1
III	MODELS of the MACHINE	2
IV	MAIN TECHNICAL PARAMETERS and OVERALL DIMENSION of the MOTOR.....	3
V	MECHANICAL CHARACTERISTICS CURVE of the MOTOR	11
VI	CONNECTION and INSTALLATION of the MOTOR.....	21
VII	STORAGE of the MOTOR	23
VIII	TRANSPORTATION of the MOTOR.....	23
IX	WARRANTY	23

I PRODUCT CHARACTERISTICS

GSK ZJY spindle servo motor is a new type of three-phase inductive motor with high performance and adopts insulation structure of F level, corona resistance enameled wire dedicated for the frequency conversion motor and the encoder with high speed and precision, and the motor is researched, developed and manufactured by GSK. The product is with the characteristics of the compact structure, high rotation precision, low noise, high reliability and high capability with low cost, etc, which can widely satisfy the requirements of the CNC machine tool and the automation.



II RUNNING CONDITIONS

- 2.1 The height above sea level should NOT exceed 1000m.
- 2.2 The environment temperature should be in the range of $-10^{\circ}\text{C} \sim +40^{\circ}\text{C}$.
- 2.3 The relative air humidity is $\leq 90\%$ (without the condensation).
- 2.4 AC voltage value of steady state is : **(0.9 ~1.1) multiplies AC rated voltage value.**

III MODELS of the MACHINE

Example: ZJY208A-5.5BH-B5A1LY1-L

ZJY	208	A	-	5.5	B	H	-	B5	A1	L	Y1	(**)	-	L
(1)	(2)	(3)		(4)	(5)	(6)		(7)	(8)	(9)	(10)	(11)		(12)

SR.NO	MEANING
(1)	The spindle servo motor
(2)	Motor width (182, 208, 265)
(3)	Design sequence number (None: Original A, B, C.....: design sequence number)
(4)	Rated power (Unit: kW)
(5)	Rated speed (T: 300 r/min, U: 450 r/min, V: 600 r/min, W: 750 r/min, A: 1000 r/min, B:1500 r/min, C: 2000 r/min, D: 2500 r/min, E: 3000 r/min)
(6)	Max. speed (F: 12000 r/min, H:10000 r/min, M:7000 r/min, L:4500 r/min)
(7)	Structure installation type: (B5 flange installation, B3 footing installation, B35 flange footing installation)
(8)	Encoder type (None: Incremental 1024 p/r, A: Incremental 2500p/r, A1: Incremental 4096 p/r, A2: Incremental 5000 p/r, A4: Absolute 17 bit, A8: Absolute 19 bit)
(9)	Look the terminal box position in view from the shaft end (None: on the top, R: on the right, L: on the left).
(10)	Shaft end (None: Optic axis, Y1: with the standard key slot)
(11)	Customer special order numbers are bracketed in two capitals.
(12)	Power supply voltage (none: three-phase 380~440V, L: three-phase 220V)

Note: ZJY182-3.7BM, ZJY208A-5.5BL and ZJY208A-7.5BL encoder types are only the incremental 1024 p/r.

Product characteristics:

- ◇ Adopt the totally enclosed air cooling structure without the case, good shape and compact structure.
- ◇ Employ the optimized electromagnetic design with the characters of the low noise, smooth running and high efficiency.
- ◇ Introduce the imported bearing in high precision, and the rotor reaches the high precision with the dynamic balance process, which can ensure the motor running stable and reliable with small vibration and low noise in the maximum rotational speed range.
- ◇ Adopt the enameled wire of corona resistance, the motor can be driven reliably at the ambient temperature of -15℃ ~ 40℃ and in the environment with the dust and oil mist.
- ◇ Employ the encoder at high speed and in high precision, and it can be incorporated into the drive with high performance for controlling the speed and the position in high precision.
- ◇ The overload capacity is strong and the motor is reliably running at rated power of 30min 150% or 5min 300%.
- ◇ The speed regulation range is wide and the maximum speed can reach 12000r/min.
- ◇ Impact resistance, long lifetime and high cost performance.
- ◇ Protection level: IP54 (GB/T 4942.1—2006)
- ◇ Insulation grade: Grade F (GB 755—2008)
- ◇ Vibration grade: Grade B (GB 10068—2008)

IV MAIN TECHNICAL PARAMETERS and OVERALL DIMENSION of the MOTOR

4.1 Refer to list 1 about the main technical parameters of three-phase 380~440V spindle motor and its overall dimension.

List 1

SPEC ITEM	ZJY182-1.5BH	ZJY182-2.2BH	ZJY182-2.2CF	ZJY182-3.7BH	ZJY182-3.7DF	ZJY182-5.5CF	ZJY182-7.5EH	ZJY182-3.7BM	ZJY208A-3.7WL	
Rated power (kW)	1.5	2.2	2.2	3.7	3.7	5.5	7.5	3.7	3.7	
Adapted GS drive type	GS3048 Y	GS3048 Y	GS3050 Y	GS3050 Y	GS3050 Y	GS3075 Y	GS3100 Y	GS3050 Y	GS3050 Y	
Drive power supply (V)	Three-phase AC 380~440V 50/60Hz									
Rated current (A)	7.3	7.5	9	15.5	13	19	21	10.4	11.3	
Rated frequency (Hz)	50	50	69	50	87	70	100	50	25	
Rated torque (N·m)	9.5	14	10.5	24	14	26	24	24	47	
30min power (kW)	2.2	3.7	3.7	5.5	5.5	7.5	11	5.5	5.5	
30min current (A)	9.3	11	14.6	19.6	19	25	30	14.8	16	
30min torque (N·m)	14	24	17.7	35	21	37	35	35	70	
Rated speed (r/min)	1500	1500	2000	1500	2500	2000	3000	1500	750	
Constant power range (r/min)	1500~8000	1500~8000	2000~10000	1500~8000	2500~10000	2000~10000	3000~9000	1500~5000	750~3000	
Max. speed (r/min)	10000	10000	12000	10000	12000	12000	10000	7000	4500	
Moment of inertia (kg·m ²)	0.0056	0.0074	0.0056	0.0115	0.0074	0.0115	0.0115	0.0093	0.0309	
Weight (kg)	27	32	27	43	32	43	43	37	77	
Installation type	IM B5 or B35									
Cooling fan power supply	Three phase AC 380~440V 50/60Hz 37W 0.1A								Three phase AC 380~440V 50/60Hz 40W 0.14A	
Overall dimension (refer to figures)	A	182	182	182	182	182	182	182	182	208
	B	91	91	91	91	91	91	91	91	104
	C	126	126	126	126	126	126	126	126	160
	D	185	185	185	185	185	185	185	185	215
	E	60	60	60	60	60	60	60	60	80
	F	324	351	324	406	351	406	406	376	524
	G	198	225	198	280	225	280	280	250	395
	H	150h7	150h7	150h7	150h7	150h7	150h7	150h7	150h7	180h7
	I	12	12	12	12	12	12	12	12	14
	J	28h6	28h6	28h6	28h6	28h6	28h6	28h6	28h6	38h6
	K	184	184	184	184	184	184	184	184	212
	L	93	93	93	93	93	93	93	93	106
	N	156	156	156	156	156	156	156	156	180
	P	32	32	32	32	32	32	32	32	40
Q	132	159	132	214	159	214	214	184	320	
S	60	60	60	60	60	60	60	60	80	
T	4	4	4	4	4	4	4	4	5	
Z	12	12	12	12	12	12	12	12	12	

List 1 (Continued)

SPEC ITEM	ZJY208A-2.2AM	ZJY208A-3.7AM	ZJY208A-5.5AM	ZJY208A-2.2BH	ZJY208A-3.7BH	ZJY208A-5.5BH	ZJY208A-7.5BH	ZJY208A-3.7BM	ZJY208A-5.5BM
Rated power (kW)	2.2	3.7	5.5	2.2	3.7	5.5	7.5	3.7	5.5
Adapted GS drive type	GS3048 Y	GS3050 Y	GS3075 Y	GS3048 Y	GS3050 Y	GS3075 Y	GS3100 Y	GS3050 Y	GS3050 Y
Drive power supply (V)	Three phase AC 380~440V 50/60Hz								
Rated current (A)	6.7	10.2	16.3	8.9	12.6	18.4	22.4	8.6	13
Rated frequency (Hz)	33.3	33.3	33.3	50	50	50	50	50	50
Rated torque (N·m)	21	35	53	14	24	35	48	24	35
30min power (kW)	3.7	5.5	7.5	3.7	5.5	7.5	11	5.5	7.5
30min current (A)	10.6	14.2	20.5	13.8	18	24	32.2	12.7	16.9
30min torque (N·m)	37	53	72	24	35	48	70	35	48
Rated speed (r/min)	1000	1000	1000	1500	1500	1500	1500	1500	1500
Constant power range (r/min)	1000~ 4000	1000~ 4000	1000~ 4000	1500~ 8000	1500~ 8000	1500~ 8000	1500~ 8000	1500~ 5000	1500~ 5000
Max. speed (r/min)	7000	7000	7000	10000	10000	10000	10000	7000	7000
Moment of inertia (kg·m ²)	0.0168	0.0238	0.0309	0.0116	0.0168	0.0238	0.0309	0.0168	0.0238
Weight (kg)	51	66	77	49	51	66	77	51	66
Installation type	IM B5 or B35								
Cooling fan power supply	Three phase AC 380~440V 50/60Hz 40W 0.14A								
Overall dimension (refer to figures)	A	208	208	208	208	208	208	208	208
	B	104	104	104	104	104	104	104	104
	C	160	160	160	160	160	160	160	160
	D	215	215	215	215	215	215	215	215
	E	60	80	80	60	60	80	80	60
	F	414	469	524	364	414	469	524	414
	G	285	340	395	235	285	340	395	285
	H	180h7	180h7	180h7	180h7	180h7	180h7	180h7	180h7
	I	14	14	14	14	14	14	14	14
	J	28h6	38h6	38h6	28h6	28h6	38h6	38h6	28h6
	K	212	212	212	212	212	212	212	212
	L	106	106	106	106	106	106	106	106
	N	180	180	180	180	180	180	180	180
	P	40	40	40	40	40	40	40	40
	Q	210	265	320	160	210	265	320	210
	S	60	80	80	53	60	80	80	60
T	5	5	5	5	5	5	5	5	
Z	12	12	12	12	12	12	12	12	

List 1 (Continued)

SPEC ITEM	ZJY208A-7.5BM	ZJY208A-5.5BL	ZJY208A-7.5BL	ZJY208A-11CM	ZJY208A-11EH	ZJY265A-5.5ML	ZJY265A-7.5ML	ZJY265A-11WL	ZJY265A-7.5AM	ZJY265A-11AM	
Rated power (kW)	7.5	5.5	7.5	11	11	5.5	7.5	11	7.5	11	
Adapted GS drive type	GS307 5Y	GS305 0Y	GS307 5Y	GS314 8Y	GS310 0Y	GS307 5Y	GS310 0Y	GS314 8Y	GS310 0Y	GS314 8Y	
Drive power supply (V)	Three phase AC 380~440V 50/60Hz										
Rated current (A)	17	12.9	17.9	28.3	25.2	16.3	21.4	30	21.5	30.9	
Rated frequency (Hz)	50	50	50	69	100	25	25	25	33.3	33.3	
Rated torque (N·m)	48	35	48	52.6	35	70	95.5	140	72	105	
30min power (kW)	11	7.5	11	15	15	7.5	11	15	11	15	
30min current (A)	24.6	16.8	24	37	31.6	20.8	30.1	41	29	40.2	
30min torque (N·m)	70	48	70	71.6	48	95.5	140	191	105	145	
Rated speed (r/min)	1500	1500	1500	2000	3000	750	750	750	1000	1000	
Constant power range (r/min)	1500~ 5000	1500~ 4500	1500~ 4500	2000~ 7000	3000~ 9000	750~3000	750~3000	750~3000	1000~ 4000	1000~ 4000	
Max. speed (r/min)	7000	4500	4500	7000	10000	4500	4500	4500	7000	7000	
Moment of inertia (kg·m ²)	0.0309	0.0168	0.0238	0.0309	0.0309	0.0744	0.0826	0.086	0.0413	0.0826	
Weight (kg)	77	52	66	77.8	66	107	125	143	89	125	
Installation type	IM B5 or B35					IM B3 or B5					
Cooling fan power supply	Three phase AC 380~440V 50/60Hz 40W 0.14A					Three phase AC 380~440V 50/60Hz 70W 0.21A					
Overall dimension (refer to figures)	A	208	208	208	208	208	265	265	265	265	
	B	104	104	104	104	104	132	132	132	132	
	C	160	160	160	160	160	185	185	185	185	
	D	215	215	215	215	215	265	265	265	265	
	E	80	80	80	110	80	110	110	110	110	
	F	524	414	469	524	469	488	533	578	443	533
	G	395	285	340	395	340	347	392	437	302	392
	H	180h7	180h7	180h7	180h7	180h7	230h7	230h7	230h7	230h7	230h7
	I	14	14	14	14	14	14	14	14	14	14
	J	38h6	38h6	38h6	48h6	38h6	48h6	48h6	55h6	48h6	48h6
	K	212	212	212	212	212	256	256	256	256	256
	L	106	106	106	106	106	135	135	135	135	135
	N	180	180	180	180	180	230	230	230	230	230
	P	40	40	40	40	40	40	40	40	40	40
Q	320	210	265	320	265	270	315	360	225	315	
S	80	80	80	110	80	110	110	110	110	110	
T	5	5	5	5	5	5	5	5	5	5	
Z	12	12	12	12	12	15	15	15	15	15	

List 1 (continued)

SPEC ITEM	ZJY265A-15AM	ZJY265A-5.5BM	ZJY265A-7.5BM	ZJY265A-11BM	ZJY265A-15BM	ZJY265A-18.5BM	ZJY265A-22BM	ZJY265A-7.5BH	ZJY265A-11BH	ZJY265A-15BH	
Rated power (kW)	15	5.5	7.5	11	15	18.5	22	7.5	11	15	
Adapted GS drive type	GS315 0Y	GS305 0Y	GS307 5Y	GS310 0Y	GS315 0Y	GS315 0Y	GS320 0Y	GS310 0Y	GS314 8Y	GS315 0Y	
Drive power supply (V)	Three phase AC 380~440V 50/60Hz										
Rated current (A)	48.3	15	18	26	35	48.7	58	21	30	40.7	
Rated frequency (Hz)	33.3	50	50	50	50	50	50	50	50	50	
Rated torque (N·m)	143	35	49	72	98	118	140	48	70	95	
30min power (kW)	18.5	7.5	11	15	18.5	22	30	11	15	18.5	
30min current (A)	56	18.7	26	34	42	54.7	73	28.5	38.3	42.7	
30min torque (N·m)	177	48	74	100	123	140	191	70	95	118	
Rated speed (r/min)	1000	1500	1500	1500	1500	1500	1500	1500	1500	1500	
Constant power range (r/min)	1000~ 4000	1500~ 5000	1500~ 5000	1500~ 5000	1500~ 5000	1500~ 5000	1500~ 5000	1500~ 8000	1500~ 8000	1500~ 8000	
Max. speed (r/min)	7000	7000	7000	7000	7000	7000	7000	10000	10000	10000	
Moment of inertia (kg·m ²)	0.086	0.0205	0.0413	0.0744	0.0826	0.086	0.102	0.0413	0.0744	0.0826	
Weight (kg)	143	62	89	107	125	143	162	89	107	125	
Installation type	IM B3 or B5										
Cooling fan power supply	Three phase AC 380~440V 50/60Hz 70W 0.21A										
Overall dimension (refer to figures)	A	265	265	265	265	265	265	265	265	265	265
	B	132	132	132	132	132	132	132	132	132	132
	C	185	185	185	185	185	185	185	185	185	185
	D	265	265	265	265	265	265	265	265	265	265
	E	110	110	110	110	110	110	110	110	110	110
	F	578	383	443	488	533	578	633	443	488	533
	G	437	242	302	347	392	437	492	302	347	392
	H	230h7	230h7	230h7	230h7	230h7	230h7	230h7	230h7	230h7	230h7
	I	14	14	14	14	14	14	14	14	14	14
	J	48h6	48h6	48h6	48h6	48h6	55h6	55h6	48h6	48h6	48h6
	K	256	256	256	256	256	256	256	256	256	256
	L	135	135	135	135	135	135	135	135	135	135
	N	230	230	230	230	230	230	230	230	230	230
	P	40	40	40	40	40	40	40	40	40	40
	Q	360	165	225	270	315	360	415	225	270	315
	S	110	110	110	110	110	110	110	110	110	110
T	5	5	5	5	5	5	5	5	5	5	
Z	15	15	15	15	15	15	15	15	15	15	

4.2 Refer to list 2 about the main technical parameters of three-phase 220V spindle motor and its overall dimension.

List 2

SPEC ITEM	ZJY182-1.5BH	ZJY182-2.2BH	ZJY182-2.2CF	ZJY182-3.7BH	ZJY182-3.7DF	ZJY182-5.5CF	ZJY208A-3.7ML	ZJY208A-2.2AM	
Rated power (kW)	1.5	2.2	2.2	3.7	3.7	5.5	3.7	2.2	
Adapted GS drive type	GS2050 Y	GS2050 Y	GS2075 Y	GS2100 Y	GS2100 Y	GS2100 Y	GS2075 Y	GS2050 Y	
Drive power supply (V)	Three phase AC 220V 50/60Hz								
Rated current (A)	10.7	12.9	14.5	23.5	22.9	32.5	19.6	11.6	
Rated frequency (Hz)	50	50	69	50	87	70	25	33.3	
Rated torque (N·m)	9.5	14	10.5	24	14	26	47	21	
30min power (kW)	2.2	3.7	3.7	5.5	5.5	7.5	5.5	3.7	
30min current (A)	17.6	20	23	36.4	33.8	47.6	27.3	18.4	
30min torque (N·m)	14	24	17.7	35	21	37	70	37	
Rated speed (r/min)	1500	1500	2000	1500	2500	2000	750	1000	
Constant power range (r/min)	1500~8000	1500~8000	2000~10000	1500~8000	2500~10000	2000~10000	750~3000	1000~4000	
Max. speed (r/min)	10000	10000	12000	10000	12000	12000	4500	7000	
Moment of inertia (kg·m ²)	0.0056	0.0074	0.0056	0.0115	0.0074	0.0115	0.0309	0.0168	
Weight (kg)	27	32	27	43	32	43	77	51	
Installation type	IM B5 or B35								
Cooling fan power supply	Three phase AC 220V 50/60Hz 37W 0.1A						Three phase AC 220V 50/60Hz 40W 0.14A		
Overall dimension (refer to figures)	A	182	182	182	182	182	182	208	208
	B	91	91	91	91	91	91	104	104
	C	126	126	126	126	126	126	160	160
	D	185	185	185	185	185	185	215	215
	E	60	60	60	60	60	60	80	60
	F	324	351	324	406	351	406	524	414
	G	198	225	198	280	225	280	395	285
	H	150h7	150h7	150h7	150h7	150h7	150h7	180h7	180h7
	I	12	12	12	12	12	12	14	14
	J	28h6	28h6	28h6	28h6	28h6	28h6	38h6	28h6
	K	184	184	184	184	184	184	212	212
	L	93	93	93	93	93	93	106	106
	N	156	156	156	156	156	156	180	180
	P	32	32	32	32	32	32	40	40
	Q	132	159	132	214	159	214	320	210
	S	60	60	60	60	60	60	80	60
T	4	4	4	4	4	4	5	5	
Z	12	12	12	12	12	12	12	12	

List 2 (Continued)

SPEC ITEM	ZJY208A-3.7AM	ZJY208A-5.5AM	ZJY208A-2.2BH	ZJY208A-3.7BH	ZJY208A-5.5BH	ZJY208A-3.7BM	ZJY208A-5.5BM	ZJY208A-7.5BM
Rated power (kW)	3.7	5.5	2.2	3.7	5.5	3.7	5.5	7.5
Adapted GS drive type	GS2075 Y	GS2100 Y	GS2075 Y	GS2100 Y	GS2100 Y	GS2075 Y	GS2100 Y	GS2100 Y
Drive power supply (V)	Three phase AC 220V 50/60Hz							
Rated current (A)	17.7	28.2	15.3	21.8	31.8	14.9	22.5	29.4
Rated frequency (Hz)	33.3	33.3	50	50	50	50	50	50
Rated torque (N·m)	35	53	14	24	35	24	35	48
30min power (kW)	5.5	7.5	3.7	5.5	7.5	5.5	7.5	11
30min current (A)	24.6	35.5	23.9	31.2	41.6	22	29.3	42.6
30min torque (N·m)	53	72	24	35	48	35	48	70
Rated speed (r/min)	1000	1000	1500	1500	1500	1500	1500	1500
Constant power range (r/min)	1000~ 4000	1000~ 4000	1500~ 8000	1500~ 8000	1500~ 8000	1500~ 5000	1500~ 5000	1500~ 5000
Max. speed (r/min)	7000	7000	10000	10000	10000	7000	7000	7000
Moment of inertia (kg·m ²)	0.0238	0.0309	0.0116	0.0168	0.0238	0.0168	0.0238	0.0309
Weight (kg)	66	77	49	51	66	51	66	77
Installation type	IM B5 or B35							
Cooling fan power supply	Three phase AC 220V 50/60Hz 40W 0.14A							
Overall dimension (refer to figures)	A	208	208	208	208	208	208	208
	B	104	104	104	104	104	104	104
	C	160	160	160	160	160	160	160
	D	215	215	215	215	215	215	215
	E	80	80	60	60	80	60	80
	F	469	524	364	414	469	414	469
	G	340	395	235	285	340	285	340
	H	180h7	180h7	180h7	180h7	180h7	180h7	180h7
	I	14	14	14	14	14	14	14
	J	38h6	38h6	28h6	28h6	38h6	28h6	38h6
	K	212	212	212	212	212	212	212
	L	106	106	106	106	106	106	106
	N	180	180	180	180	180	180	180
	P	40	40	40	40	40	40	40
	Q	265	320	160	210	265	210	265
S	80	80	53	60	80	60	80	
T	5	5	5	5	5	5	5	
Z	12	12	12	12	12	12	12	

4.3 About the outline drawings of the motors of various installation types please refer to the following figures.

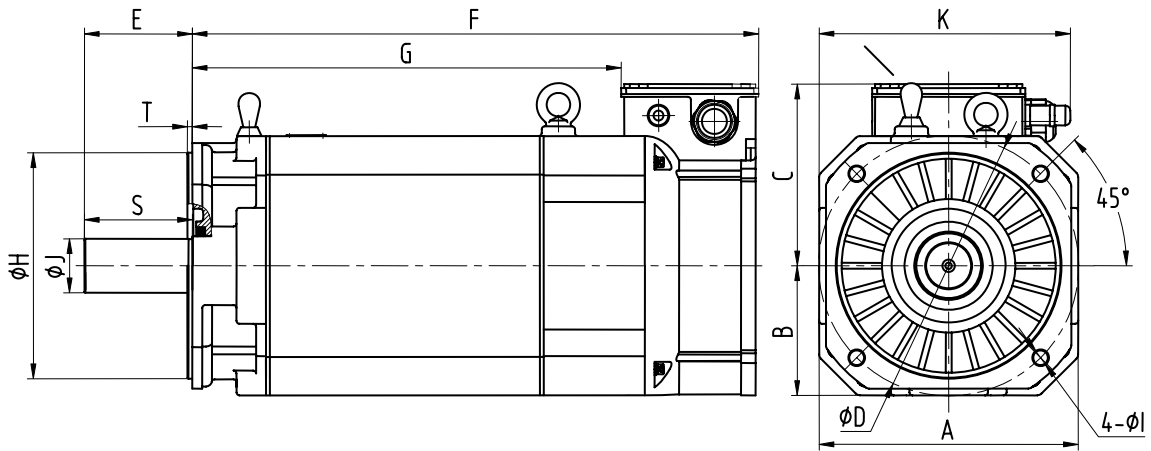

Flange installation type (B5)

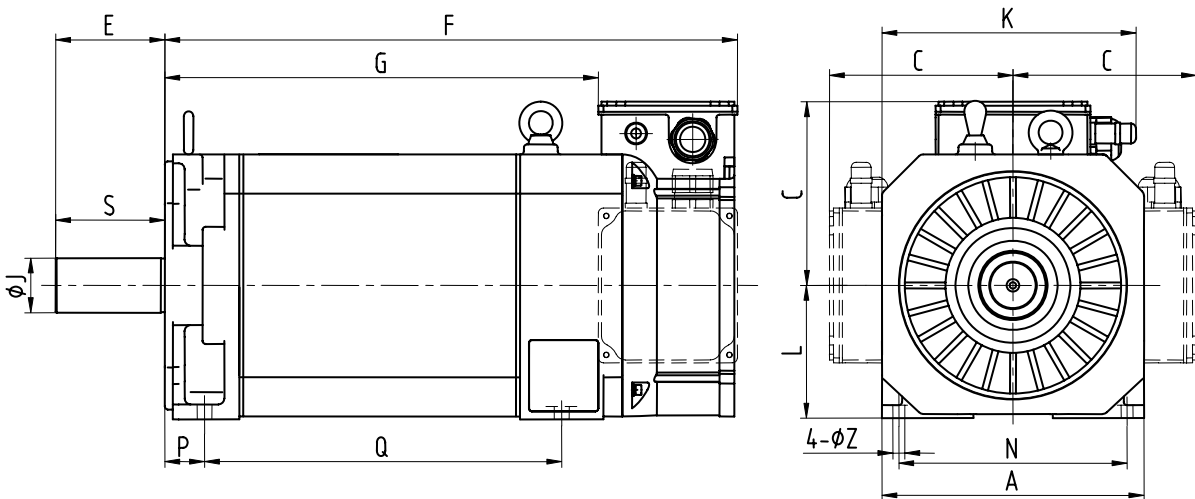

Footing installation type (B3) and left & right outlet method

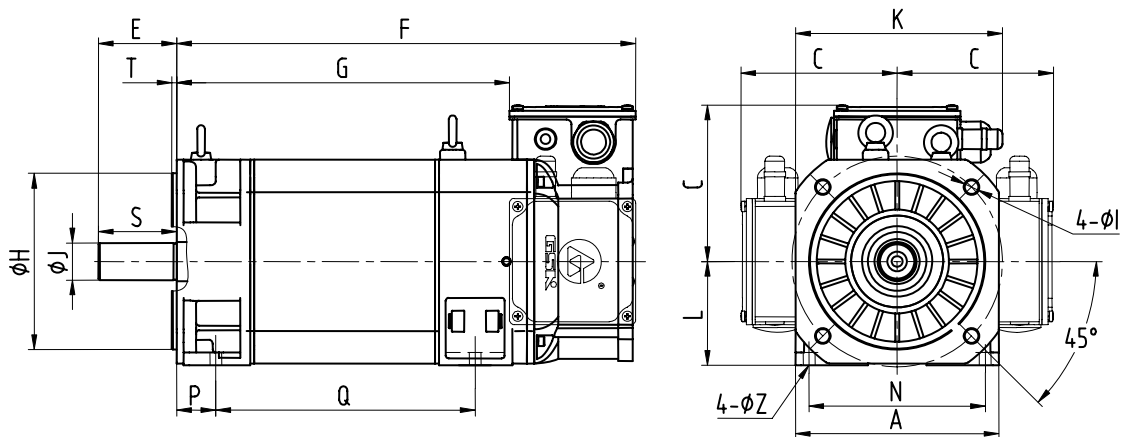

Flange & footing installation type (B35) and left & right outlet method

4.4 Dimension of the Standard Key Slot

4.4.1 ZJY182-3.7BM, ZJY208A-3.7BM, ZJY208A-2.2AM

The configuration keys: GB/T 1096 Key: 8×7×50

About the dimension of the shaft end key slot, refer to the following left figure; And the central screw hole dimension on the end face of the rotary axis is M10×20.

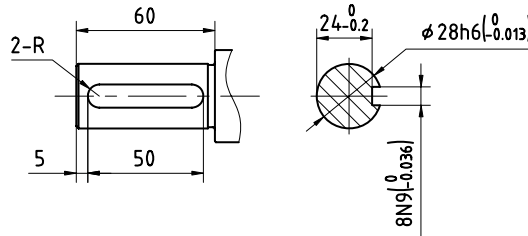

4.4.2 ZJY208A-5.5BM, ZJY208A-7.5BM, ZJY208A-5.5BL, ZJY208A-7.5BL,

ZJY208A-3.7AM, ZJY208A-3.7WL, ZJY208A-5.5AM

The configuration keys: GB/T 1096 Key: 10×8×70

About the dimension of the shaft end key slot, refer to the following figure; and the central screw hole dimension on the end face of the rotary axis is M10×20.

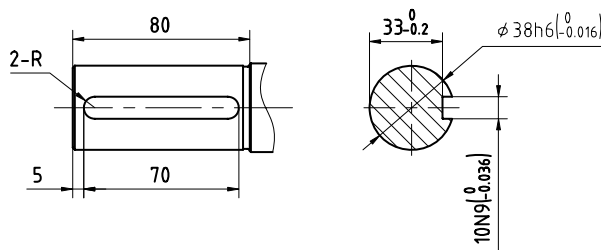

4.4.3 ZJY265A-5.5WL, ZJY265A-7.5WL, ZJY265A-5.5BM, ZJY265A-7.5BM, ZJY265A-11BM, ZJY265A-15BM, ZJY265A-7.5AM, ZJY265A-11AM, ZJY265A-15AM, ZJY208A-11CM

The configuration keys: GB/T 1096 Key: 14×9×90

About the dimension of the shaft end key slot, refer to the following figure; and the central screw hole dimension on the end face of the rotary axis is M10×20.

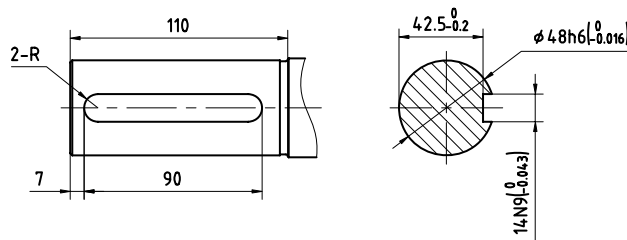

4.4.4 ZJY265A-11WL, ZJY265A-18.5BM, ZJY265A-22BM

The configuration keys: GB/T 1096 Key: 16×10×90

About the dimension of the shaft end key slot, refer to the following figure; and the central screw hole dimension on the end face of the rotary axis is M10×20.

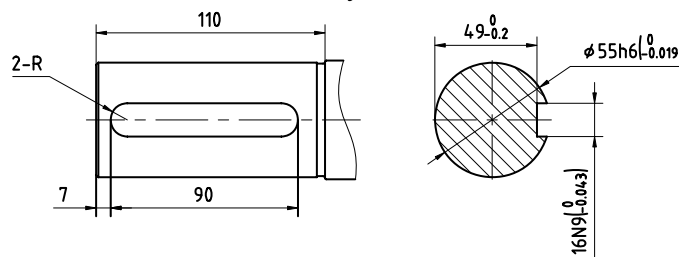

V MECHANICAL CHARACTERISTICS CURVE of the MOTOR

Figure:

———— Power or torque in the continuous working state;

- - - - - Power or torque in 30min working state.

Motor type	Power curve	Torque curve
ZJY182-1.5BH		
ZJY182-2.2BH		
ZJY182-2.2CF		

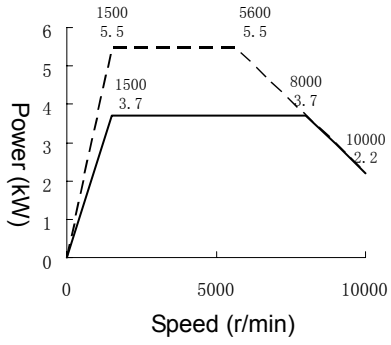
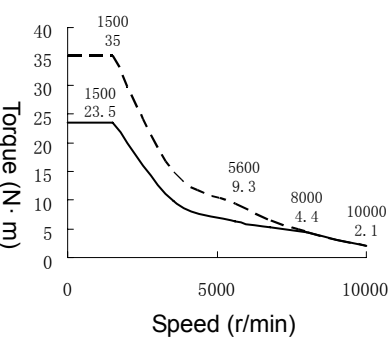
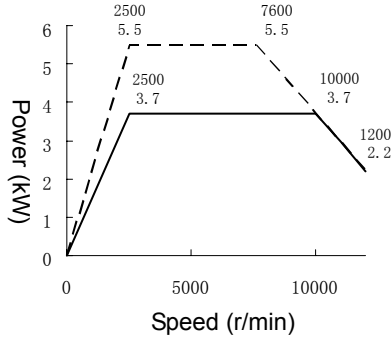
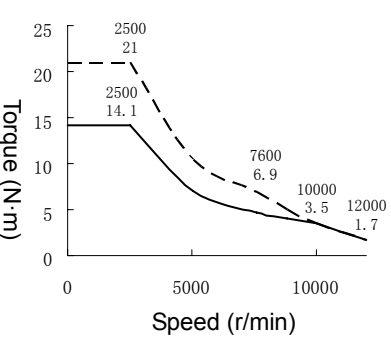
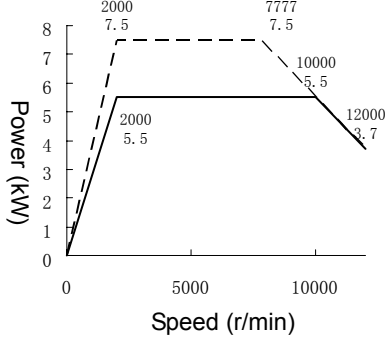
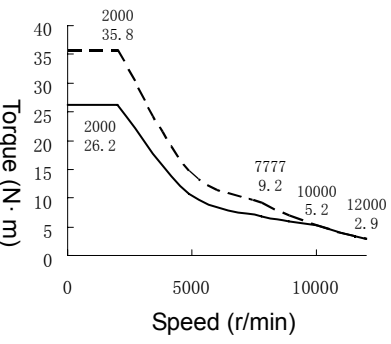
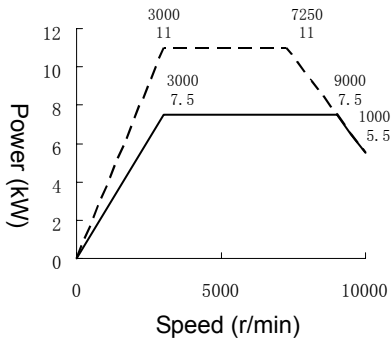
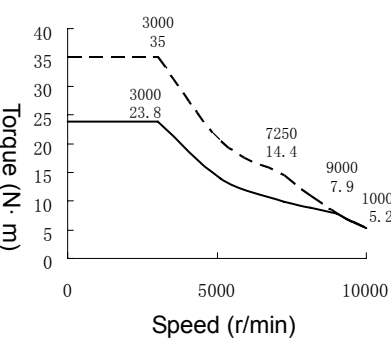
Motor type	Power curve	Torque curve
ZJY182-3.7BH	 <p>Power (kW) vs Speed (r/min) for ZJY182-3.7BH. The graph shows two curves: a solid line for continuous power and a dashed line for maximum power. Key data points are: (1500, 5.5), (1500, 3.7), (5600, 5.5), (8000, 3.7), and (10000, 2.2).</p>	 <p>Torque (N·m) vs Speed (r/min) for ZJY182-3.7BH. The graph shows two curves: a solid line for continuous torque and a dashed line for maximum torque. Key data points are: (1500, 35), (1500, 23.5), (5600, 9.3), (8000, 4.4), and (10000, 2.1).</p>
ZJY182-3.7DF	 <p>Power (kW) vs Speed (r/min) for ZJY182-3.7DF. The graph shows two curves: a solid line for continuous power and a dashed line for maximum power. Key data points are: (2500, 5.5), (2500, 3.7), (7600, 5.5), (10000, 3.7), and (12000, 2.2).</p>	 <p>Torque (N·m) vs Speed (r/min) for ZJY182-3.7DF. The graph shows two curves: a solid line for continuous torque and a dashed line for maximum torque. Key data points are: (2500, 21), (2500, 14.1), (7600, 6.9), (10000, 3.5), and (12000, 1.7).</p>
ZJY182-5.5CF	 <p>Power (kW) vs Speed (r/min) for ZJY182-5.5CF. The graph shows two curves: a solid line for continuous power and a dashed line for maximum power. Key data points are: (2000, 7.5), (2000, 5.5), (7777, 7.5), (10000, 5.5), and (12000, 3.7).</p>	 <p>Torque (N·m) vs Speed (r/min) for ZJY182-5.5CF. The graph shows two curves: a solid line for continuous torque and a dashed line for maximum torque. Key data points are: (2000, 35.8), (2000, 26.2), (7777, 9.2), (10000, 5.2), and (12000, 2.9).</p>
ZJY182-7.5EH	 <p>Power (kW) vs Speed (r/min) for ZJY182-7.5EH. The graph shows two curves: a solid line for continuous power and a dashed line for maximum power. Key data points are: (3000, 11), (3000, 7.5), (7250, 11), (9000, 7.5), and (10000, 5.5).</p>	 <p>Torque (N·m) vs Speed (r/min) for ZJY182-7.5EH. The graph shows two curves: a solid line for continuous torque and a dashed line for maximum torque. Key data points are: (3000, 35), (3000, 23.8), (7250, 14.4), (9000, 7.9), and (10000, 5.2).</p>

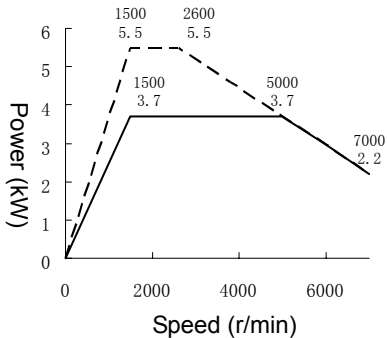
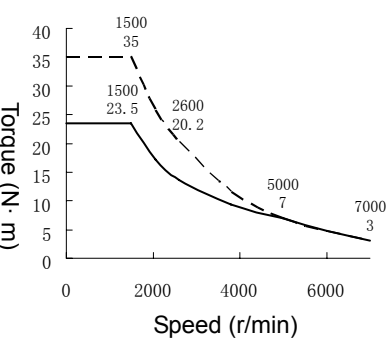
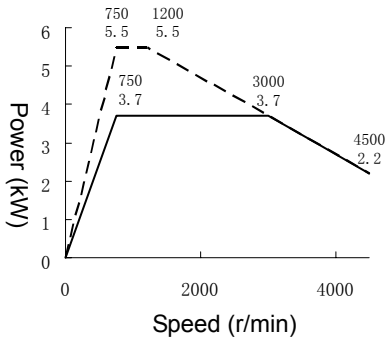
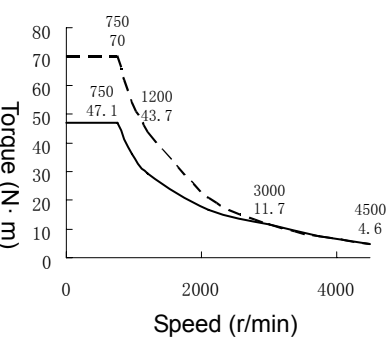
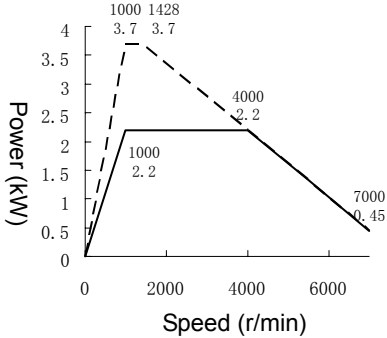
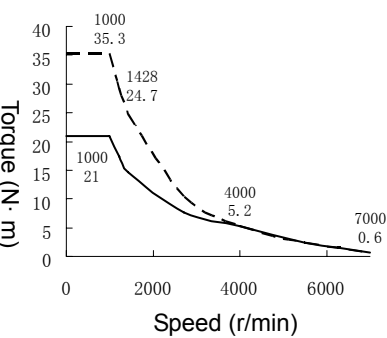
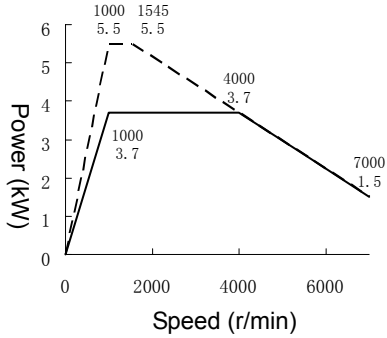
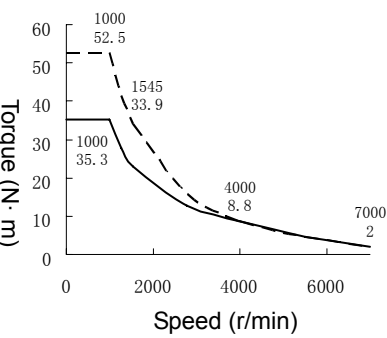
Motor type	Power curve	Torque curve
ZJY182-3.7BM	 <p>Power (kW) vs Speed (r/min) for ZJY182-3.7BM. The graph shows a solid line for rated power and a dashed line for maximum power. Key data points are: (1500, 3.7), (2600, 5.5), (5000, 3.7), and (7000, 2.2).</p>	 <p>Torque (N·m) vs Speed (r/min) for ZJY182-3.7BM. The graph shows a solid line for rated torque and a dashed line for maximum torque. Key data points are: (1500, 23.5), (2600, 35), (5000, 7), and (7000, 3).</p>
ZJY208A-3.7WL	 <p>Power (kW) vs Speed (r/min) for ZJY208A-3.7WL. The graph shows a solid line for rated power and a dashed line for maximum power. Key data points are: (750, 3.7), (1200, 5.5), (3000, 3.7), and (4500, 2.2).</p>	 <p>Torque (N·m) vs Speed (r/min) for ZJY208A-3.7WL. The graph shows a solid line for rated torque and a dashed line for maximum torque. Key data points are: (750, 47.1), (1200, 70), (3000, 11.7), and (4500, 4.6).</p>
ZJY208A-2.2AM	 <p>Power (kW) vs Speed (r/min) for ZJY208A-2.2AM. The graph shows a solid line for rated power and a dashed line for maximum power. Key data points are: (1000, 2.2), (1428, 3.7), (4000, 2.2), and (7000, 0.45).</p>	 <p>Torque (N·m) vs Speed (r/min) for ZJY208A-2.2AM. The graph shows a solid line for rated torque and a dashed line for maximum torque. Key data points are: (1000, 21), (1428, 35.3), (4000, 5.2), and (7000, 0.6).</p>
ZJY208A-3.7AM	 <p>Power (kW) vs Speed (r/min) for ZJY208A-3.7AM. The graph shows a solid line for rated power and a dashed line for maximum power. Key data points are: (1000, 3.7), (1545, 5.5), (4000, 3.7), and (7000, 1.5).</p>	 <p>Torque (N·m) vs Speed (r/min) for ZJY208A-3.7AM. The graph shows a solid line for rated torque and a dashed line for maximum torque. Key data points are: (1000, 35.3), (1545, 52.5), (4000, 8.8), and (7000, 2).</p>

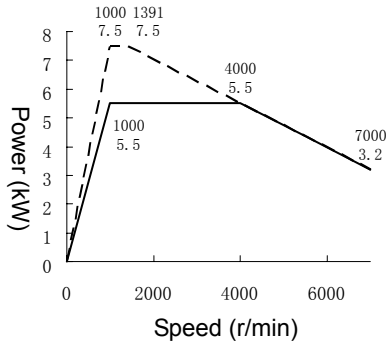
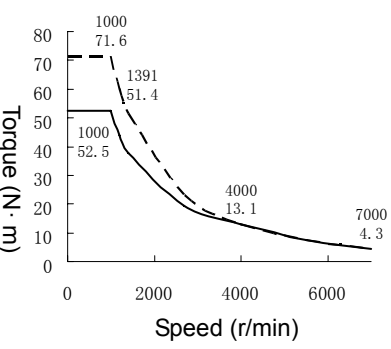
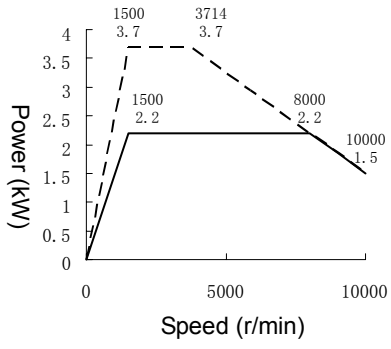
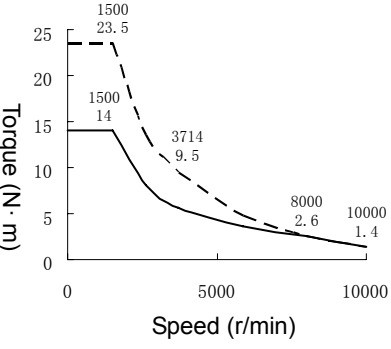
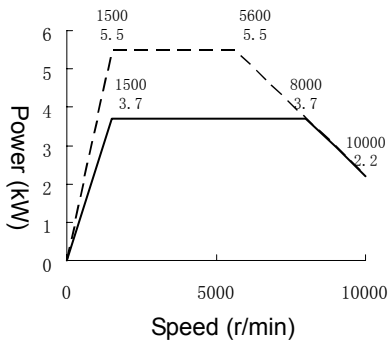
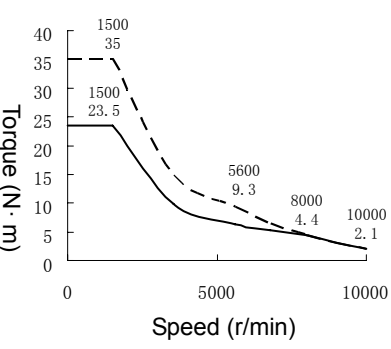
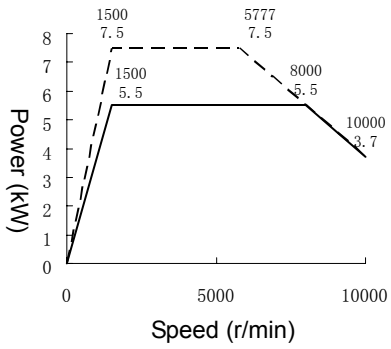
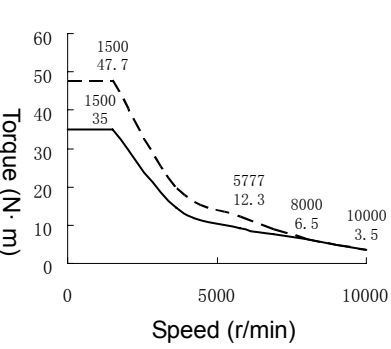
Motor type	Power curve	Torque curve
ZJY208A-5.5AM	 <p>Power (kW) vs Speed (r/min) for ZJY208A-5.5AM. The graph shows a solid line for rated power and a dashed line for maximum power. Key data points are: (1000, 5.5), (1391, 7.5), (4000, 5.5), and (7000, 3.2).</p>	 <p>Torque (N·m) vs Speed (r/min) for ZJY208A-5.5AM. The graph shows a solid line for rated torque and a dashed line for maximum torque. Key data points are: (1000, 52.5), (1391, 51.4), (4000, 13.1), and (7000, 4.3).</p>
ZJY208A-2.2BH	 <p>Power (kW) vs Speed (r/min) for ZJY208A-2.2BH. The graph shows a solid line for rated power and a dashed line for maximum power. Key data points are: (1500, 2.2), (3714, 3.7), (8000, 2.2), and (10000, 1.5).</p>	 <p>Torque (N·m) vs Speed (r/min) for ZJY208A-2.2BH. The graph shows a solid line for rated torque and a dashed line for maximum torque. Key data points are: (1500, 14), (3714, 9.5), (8000, 2.6), and (10000, 1.4).</p>
ZJY208A-3.7BH	 <p>Power (kW) vs Speed (r/min) for ZJY208A-3.7BH. The graph shows a solid line for rated power and a dashed line for maximum power. Key data points are: (1500, 3.7), (5600, 5.5), (8000, 3.7), and (10000, 2.2).</p>	 <p>Torque (N·m) vs Speed (r/min) for ZJY208A-3.7BH. The graph shows a solid line for rated torque and a dashed line for maximum torque. Key data points are: (1500, 23.5), (5600, 9.3), (8000, 4.4), and (10000, 2.1).</p>
ZJY208A-5.5BH	 <p>Power (kW) vs Speed (r/min) for ZJY208A-5.5BH. The graph shows a solid line for rated power and a dashed line for maximum power. Key data points are: (1500, 5.5), (5777, 7.5), (8000, 5.5), and (10000, 3.7).</p>	 <p>Torque (N·m) vs Speed (r/min) for ZJY208A-5.5BH. The graph shows a solid line for rated torque and a dashed line for maximum torque. Key data points are: (1500, 35), (5777, 12.3), (8000, 6.5), and (10000, 3.5).</p>

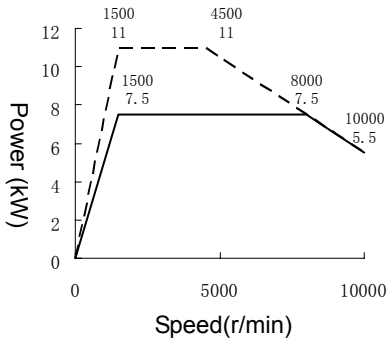
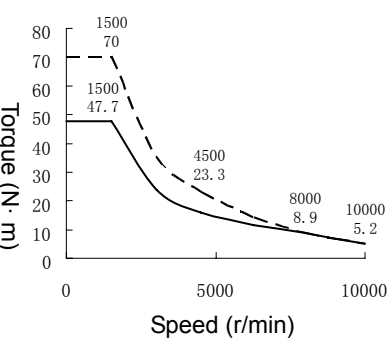
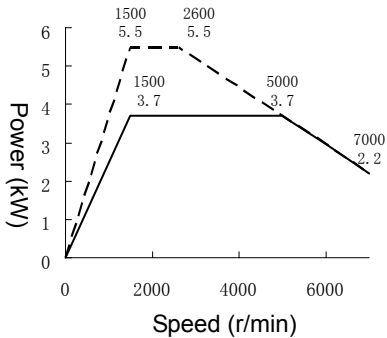
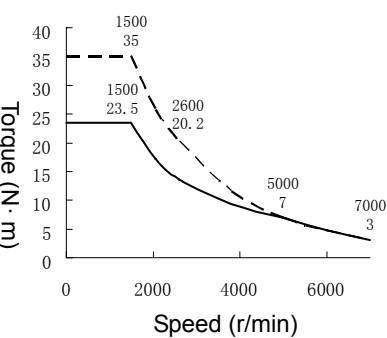
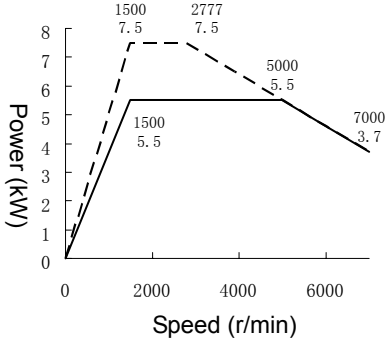
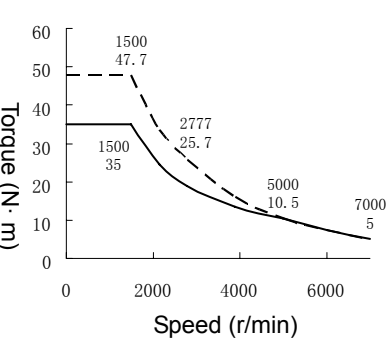
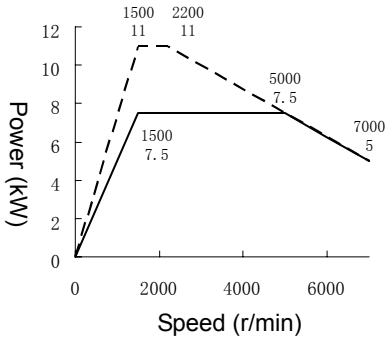
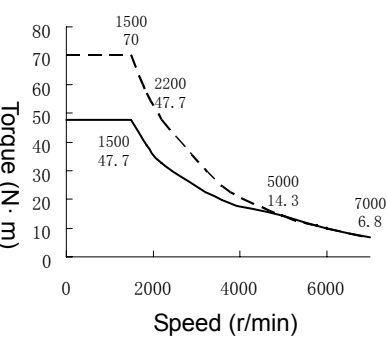
Motor type	Power curve	Torque curve
ZJY208A-7.5BH	 <p>Power (kW) vs Speed (r/min) for ZJY208A-7.5BH. The graph shows a solid line for continuous power and a dashed line for maximum power. Key data points are: (1500, 7.5), (1500, 11), (4500, 11), (8000, 7.5), and (10000, 5.5).</p>	 <p>Torque (N·m) vs Speed (r/min) for ZJY208A-7.5BH. The graph shows a solid line for continuous torque and a dashed line for maximum torque. Key data points are: (1500, 47.7), (1500, 70), (4500, 23.3), (8000, 8.9), and (10000, 5.2).</p>
ZJY208A-3.7BM	 <p>Power (kW) vs Speed (r/min) for ZJY208A-3.7BM. The graph shows a solid line for continuous power and a dashed line for maximum power. Key data points are: (1500, 3.7), (1500, 5.5), (2600, 5.5), (5000, 3.7), and (7000, 2.2).</p>	 <p>Torque (N·m) vs Speed (r/min) for ZJY208A-3.7BM. The graph shows a solid line for continuous torque and a dashed line for maximum torque. Key data points are: (1500, 23.5), (1500, 35), (2600, 20.2), (5000, 7), and (7000, 3).</p>
ZJY208A-5.5BM	 <p>Power (kW) vs Speed (r/min) for ZJY208A-5.5BM. The graph shows a solid line for continuous power and a dashed line for maximum power. Key data points are: (1500, 5.5), (1500, 7.5), (2777, 7.5), (5000, 5.5), and (7000, 3.7).</p>	 <p>Torque (N·m) vs Speed (r/min) for ZJY208A-5.5BM. The graph shows a solid line for continuous torque and a dashed line for maximum torque. Key data points are: (1500, 35), (1500, 47.7), (2777, 25.7), (5000, 10.5), and (7000, 5).</p>
ZJY208A-7.5BM	 <p>Power (kW) vs Speed (r/min) for ZJY208A-7.5BM. The graph shows a solid line for continuous power and a dashed line for maximum power. Key data points are: (1500, 7.5), (1500, 11), (2200, 11), (5000, 7.5), and (7000, 5).</p>	 <p>Torque (N·m) vs Speed (r/min) for ZJY208A-7.5BM. The graph shows a solid line for continuous torque and a dashed line for maximum torque. Key data points are: (1500, 47.7), (1500, 70), (2200, 47.7), (5000, 14.3), and (7000, 6.8).</p>

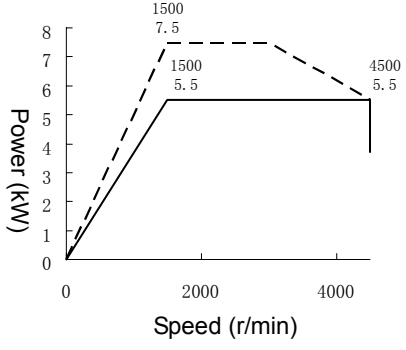
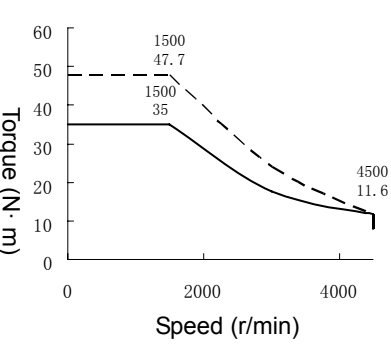
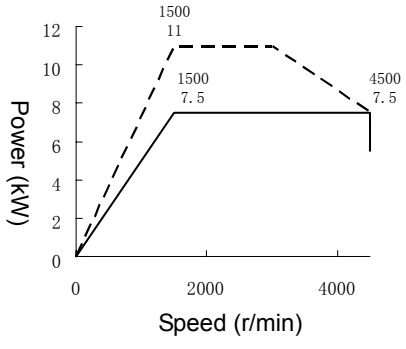
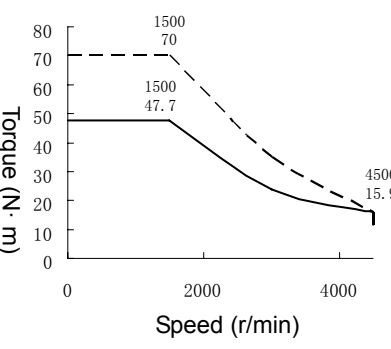
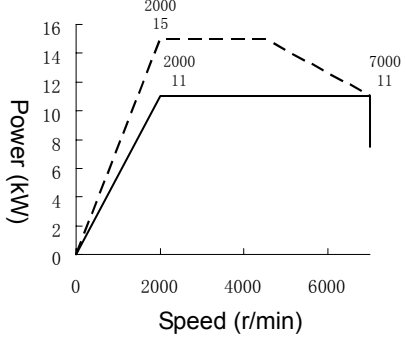
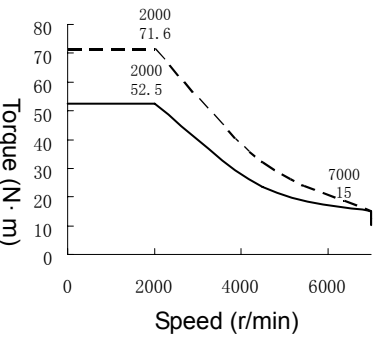
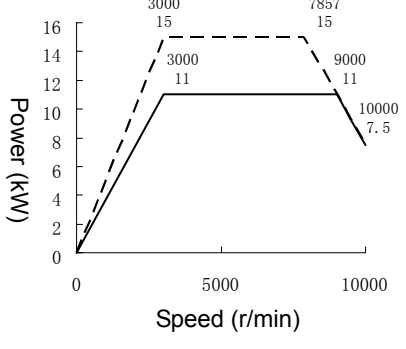
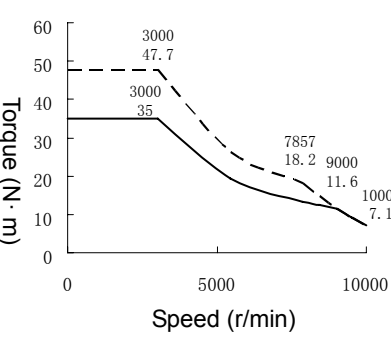
Motor type	Power curve	Torque curve
ZJY208A-5.5BL	 <p>Power (kW) vs Speed (r/min) for ZJY208A-5.5BL. The graph shows two curves: a solid line for rated power and a dashed line for maximum power. The rated power is 5.5 kW at 1500 r/min and remains constant up to 4500 r/min. The maximum power is 7.5 kW at 1500 r/min.</p>	 <p>Torque (N·m) vs Speed (r/min) for ZJY208A-5.5BL. The graph shows two curves: a solid line for rated torque and a dashed line for maximum torque. The rated torque is 35 N·m at 1500 r/min and decreases to 11.6 N·m at 4500 r/min. The maximum torque is 47.7 N·m at 1500 r/min.</p>
ZJY208A-7.5BL	 <p>Power (kW) vs Speed (r/min) for ZJY208A-7.5BL. The graph shows two curves: a solid line for rated power and a dashed line for maximum power. The rated power is 7.5 kW at 1500 r/min and remains constant up to 4500 r/min. The maximum power is 11 kW at 1500 r/min.</p>	 <p>Torque (N·m) vs Speed (r/min) for ZJY208A-7.5BL. The graph shows two curves: a solid line for rated torque and a dashed line for maximum torque. The rated torque is 47.7 N·m at 1500 r/min and decreases to 15.9 N·m at 4500 r/min. The maximum torque is 70 N·m at 1500 r/min.</p>
ZJY208A-11CM	 <p>Power (kW) vs Speed (r/min) for ZJY208A-11CM. The graph shows two curves: a solid line for rated power and a dashed line for maximum power. The rated power is 11 kW at 2000 r/min and remains constant up to 7000 r/min. The maximum power is 15 kW at 2000 r/min.</p>	 <p>Torque (N·m) vs Speed (r/min) for ZJY208A-11CM. The graph shows two curves: a solid line for rated torque and a dashed line for maximum torque. The rated torque is 52.5 N·m at 2000 r/min and decreases to 15 N·m at 7000 r/min. The maximum torque is 71.6 N·m at 2000 r/min.</p>
ZJY208A-11EH	 <p>Power (kW) vs Speed (r/min) for ZJY208A-11EH. The graph shows two curves: a solid line for rated power and a dashed line for maximum power. The rated power is 11 kW at 3000 r/min and remains constant up to 10000 r/min. The maximum power is 15 kW at 3000 r/min.</p>	 <p>Torque (N·m) vs Speed (r/min) for ZJY208A-11EH. The graph shows two curves: a solid line for rated torque and a dashed line for maximum torque. The rated torque is 35 N·m at 3000 r/min and decreases to 7.1 N·m at 10000 r/min. The maximum torque is 47.7 N·m at 3000 r/min.</p>

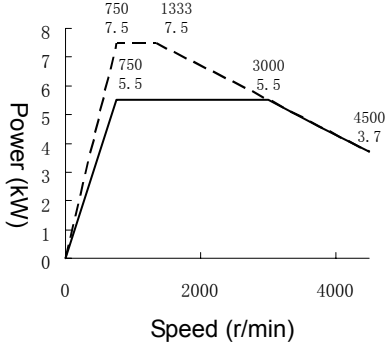
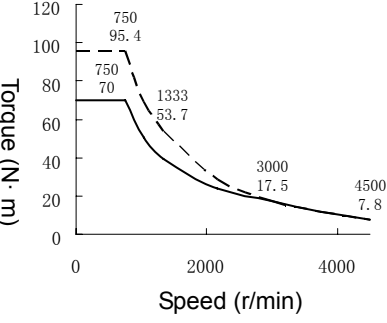
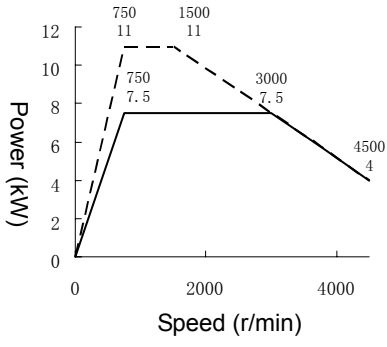
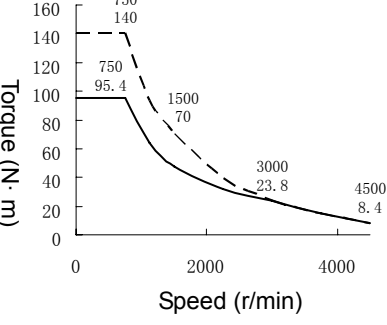
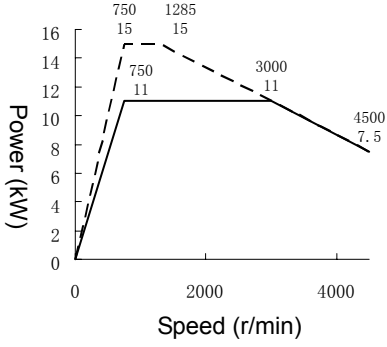
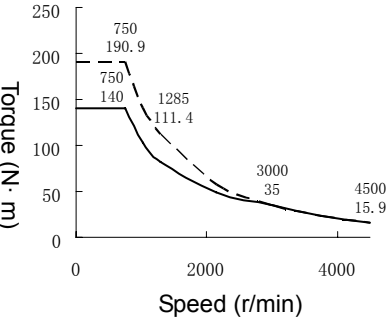
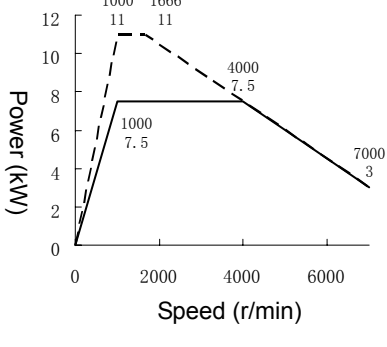
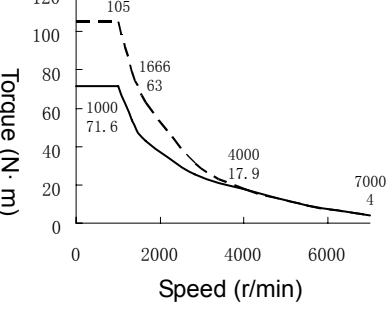
Motor type	Power curve	Torque curve
ZJY265A-5.5WL	 <p>Power (kW) vs Speed (r/min) for ZJY265A-5.5WL. The graph shows a solid line for continuous power and a dashed line for maximum power. Key data points are: (750, 7.5), (1333, 7.5), (3000, 5.5), and (4500, 3.7).</p>	 <p>Torque (N·m) vs Speed (r/min) for ZJY265A-5.5WL. The graph shows a solid line for continuous torque and a dashed line for maximum torque. Key data points are: (750, 95.4), (750, 70), (1333, 53.7), (3000, 17.5), and (4500, 7.8).</p>
ZJY265A-7.5WL	 <p>Power (kW) vs Speed (r/min) for ZJY265A-7.5WL. The graph shows a solid line for continuous power and a dashed line for maximum power. Key data points are: (750, 11), (1500, 11), (3000, 7.5), and (4500, 4).</p>	 <p>Torque (N·m) vs Speed (r/min) for ZJY265A-7.5WL. The graph shows a solid line for continuous torque and a dashed line for maximum torque. Key data points are: (750, 140), (750, 95.4), (1500, 70), (3000, 23.8), and (4500, 8.4).</p>
ZJY265A-11WL	 <p>Power (kW) vs Speed (r/min) for ZJY265A-11WL. The graph shows a solid line for continuous power and a dashed line for maximum power. Key data points are: (750, 15), (1285, 15), (3000, 11), and (4500, 7.5).</p>	 <p>Torque (N·m) vs Speed (r/min) for ZJY265A-11WL. The graph shows a solid line for continuous torque and a dashed line for maximum torque. Key data points are: (750, 190.9), (750, 140), (1285, 111.4), (3000, 35), and (4500, 15.9).</p>
ZJY265A-7.5AM	 <p>Power (kW) vs Speed (r/min) for ZJY265A-7.5AM. The graph shows a solid line for continuous power and a dashed line for maximum power. Key data points are: (1000, 11), (1666, 11), (4000, 7.5), and (7000, 3).</p>	 <p>Torque (N·m) vs Speed (r/min) for ZJY265A-7.5AM. The graph shows a solid line for continuous torque and a dashed line for maximum torque. Key data points are: (1000, 105), (1000, 71.6), (1666, 63), (4000, 17.9), and (7000, 4).</p>

Motor type	Power curve	Torque curve
ZJY265A-11AM	<p>Power (kW) vs Speed (r/min) for ZJY265A-11AM. The solid line represents rated power (11 kW) from 1000 to 4000 rpm. The dashed line represents maximum power (15 kW) from 1000 to 1600 rpm. At 7000 rpm, the power is 6 kW.</p>	<p>Torque (N·m) vs Speed (r/min) for ZJY265A-11AM. The solid line represents rated torque (105 N·m) from 1000 to 1600 rpm. The dashed line represents maximum torque (143.2 N·m) at 1000 rpm. At 7000 rpm, the torque is 8.1 N·m.</p>
ZJY265A-15AM	<p>Power (kW) vs Speed (r/min) for ZJY265A-15AM. The solid line represents rated power (15 kW) from 1000 to 4000 rpm. The dashed line represents maximum power (18.5 kW) from 1000 to 1900 rpm. At 7000 rpm, the power is 10 kW.</p>	<p>Torque (N·m) vs Speed (r/min) for ZJY265A-15AM. The solid line represents rated torque (143.2 N·m) from 1000 to 1900 rpm. The dashed line represents maximum torque (176.6 N·m) at 1000 rpm. At 7000 rpm, the torque is 13.6 N·m.</p>
ZJY265A-5.5BM	<p>Power (kW) vs Speed (r/min) for ZJY265A-5.5BM. The solid line represents rated power (5.5 kW) from 1500 to 5000 rpm. The dashed line represents maximum power (7.5 kW) from 1500 to 2777 rpm. At 7000 rpm, the power is 3.7 kW.</p>	<p>Torque (N·m) vs Speed (r/min) for ZJY265A-5.5BM. The solid line represents rated torque (35 N·m) from 1500 to 2777 rpm. The dashed line represents maximum torque (47.7 N·m) at 1500 rpm. At 7000 rpm, the torque is 5 N·m.</p>
ZJY265A-7.5BM	<p>Power (kW) vs Speed (r/min) for ZJY265A-7.5BM. The solid line represents rated power (7.5 kW) from 1500 to 5000 rpm. The dashed line represents maximum power (11 kW) from 1500 to 2200 rpm. At 7000 rpm, the power is 5 kW.</p>	<p>Torque (N·m) vs Speed (r/min) for ZJY265A-7.5BM. The solid line represents rated torque (47.7 N·m) from 1500 to 2200 rpm. The dashed line represents maximum torque (70 N·m) at 1500 rpm. At 7000 rpm, the torque is 6.8 N·m.</p>

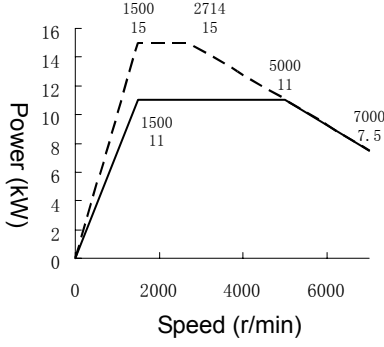
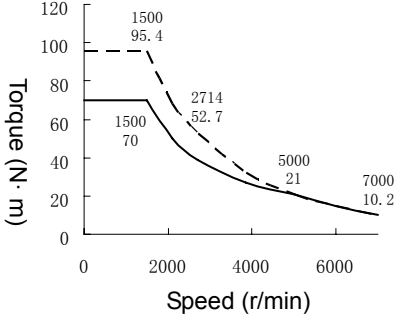
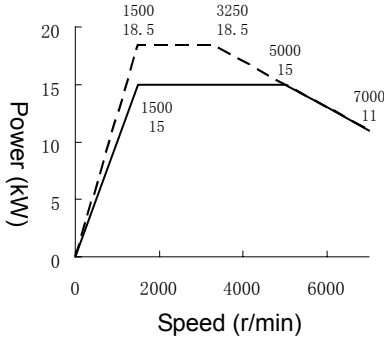
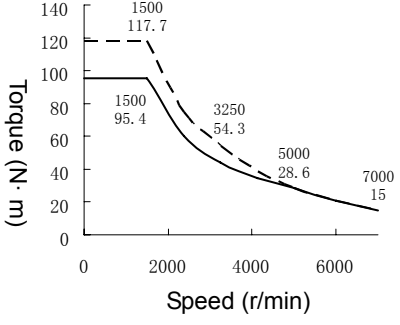
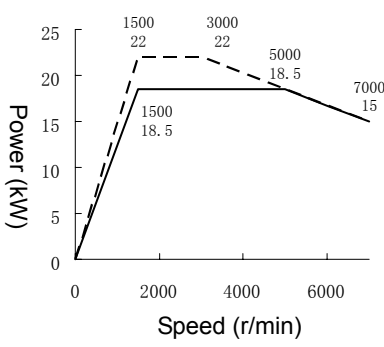
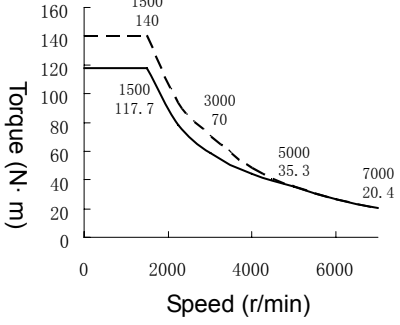
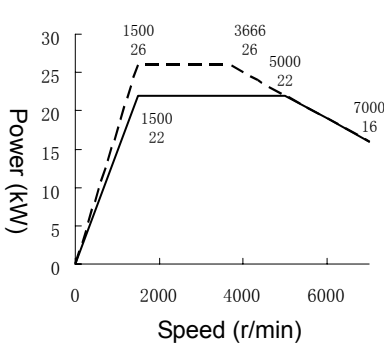
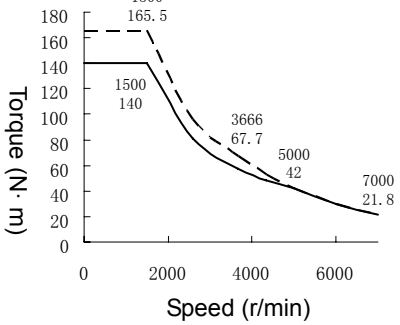
Motor type	Power curve	Torque curve
ZJY265A-11BM	 <p>Power (kW) vs Speed (r/min) for ZJY265A-11BM. The graph shows a solid line for rated power and a dashed line for maximum power. Key points are: (1500, 11) and (1500, 15) for the solid line; (2714, 15) for the dashed line; (5000, 11) and (7000, 7.5) for the solid line.</p>	 <p>Torque (N·m) vs Speed (r/min) for ZJY265A-11BM. The graph shows a solid line for rated torque and a dashed line for maximum torque. Key points are: (1500, 70) and (1500, 95.4) for the solid line; (2714, 52.7) for the dashed line; (5000, 21) and (7000, 10.2) for the solid line.</p>
ZJY265A-15BM	 <p>Power (kW) vs Speed (r/min) for ZJY265A-15BM. The graph shows a solid line for rated power and a dashed line for maximum power. Key points are: (1500, 15) and (1500, 18.5) for the solid line; (3250, 18.5) for the dashed line; (5000, 15) and (7000, 11) for the solid line.</p>	 <p>Torque (N·m) vs Speed (r/min) for ZJY265A-15BM. The graph shows a solid line for rated torque and a dashed line for maximum torque. Key points are: (1500, 95.4) and (1500, 117.7) for the solid line; (3250, 54.3) for the dashed line; (5000, 28.6) and (7000, 15) for the solid line.</p>
ZJY265A-18.5BM	 <p>Power (kW) vs Speed (r/min) for ZJY265A-18.5BM. The graph shows a solid line for rated power and a dashed line for maximum power. Key points are: (1500, 18.5) and (1500, 22) for the solid line; (3000, 22) for the dashed line; (5000, 18.5) and (7000, 15) for the solid line.</p>	 <p>Torque (N·m) vs Speed (r/min) for ZJY265A-18.5BM. The graph shows a solid line for rated torque and a dashed line for maximum torque. Key points are: (1500, 117.7) and (1500, 140) for the solid line; (3000, 70) for the dashed line; (5000, 35.3) and (7000, 20.4) for the solid line.</p>
ZJY265A-22BM	 <p>Power (kW) vs Speed (r/min) for ZJY265A-22BM. The graph shows a solid line for rated power and a dashed line for maximum power. Key points are: (1500, 22) and (1500, 26) for the solid line; (3666, 26) for the dashed line; (5000, 22) and (7000, 16) for the solid line.</p>	 <p>Torque (N·m) vs Speed (r/min) for ZJY265A-22BM. The graph shows a solid line for rated torque and a dashed line for maximum torque. Key points are: (1500, 140) and (1500, 165.5) for the solid line; (3666, 67.7) for the dashed line; (5000, 42) and (7000, 21.8) for the solid line.</p>

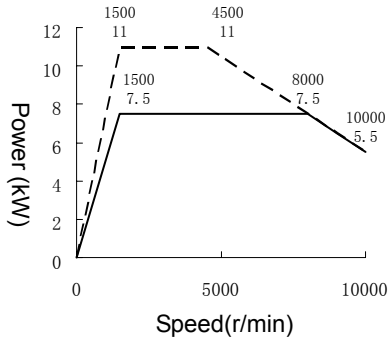
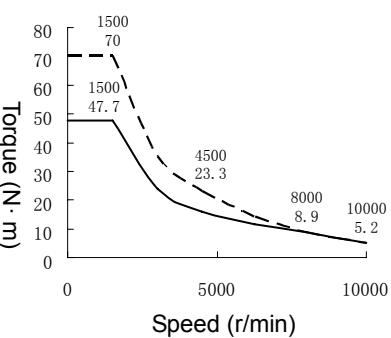
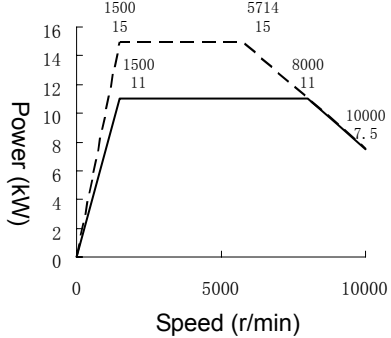
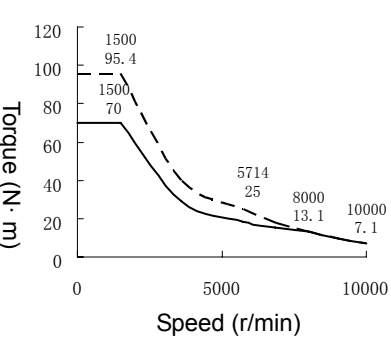
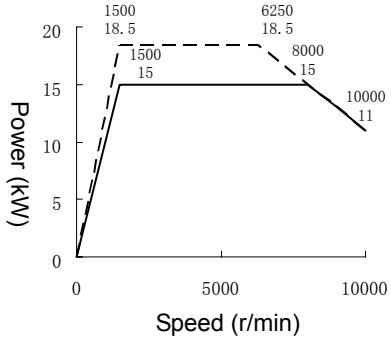
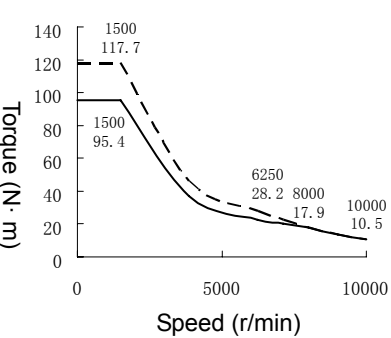
Motor type	Power curve	Torque curve
ZJY265A-7.5BH	 <p>Power (kW) vs Speed (r/min) for ZJY265A-7.5BH. The graph shows a solid line for rated power (7.5 kW) and a dashed line for maximum power (11 kW). Key points are labeled: (1500, 11), (4500, 11), (8000, 7.5), and (10000, 5.5).</p>	 <p>Torque (N·m) vs Speed (r/min) for ZJY265A-7.5BH. The graph shows a solid line for rated torque (47.7 N·m) and a dashed line for maximum torque (70 N·m). Key points are labeled: (1500, 70), (1500, 47.7), (4500, 23.3), (8000, 8.9), and (10000, 5.2).</p>
ZJY265A-11BH	 <p>Power (kW) vs Speed (r/min) for ZJY265A-11BH. The graph shows a solid line for rated power (11 kW) and a dashed line for maximum power (15 kW). Key points are labeled: (1500, 15), (5714, 15), (8000, 11), and (10000, 7.5).</p>	 <p>Torque (N·m) vs Speed (r/min) for ZJY265A-11BH. The graph shows a solid line for rated torque (70 N·m) and a dashed line for maximum torque (95.4 N·m). Key points are labeled: (1500, 95.4), (1500, 70), (5714, 25), (8000, 13.1), and (10000, 7.1).</p>
ZJY265A-15BH	 <p>Power (kW) vs Speed (r/min) for ZJY265A-15BH. The graph shows a solid line for rated power (15 kW) and a dashed line for maximum power (18.5 kW). Key points are labeled: (1500, 18.5), (6250, 18.5), (8000, 15), and (10000, 11).</p>	 <p>Torque (N·m) vs Speed (r/min) for ZJY265A-15BH. The graph shows a solid line for rated torque (95.4 N·m) and a dashed line for maximum torque (117.7 N·m). Key points are labeled: (1500, 117.7), (1500, 95.4), (6250, 28.2), (8000, 17.9), and (10000, 10.5).</p>

VI CONNECTION and INSTALLATION of the MOTOR

6.1 Connection of the motor and the drive

6.1.1 The three-phase winding of the motor U, V, W and the case (GND) are led out by the cable fixed head, and about the position relation in the terminal box, refer to the following figure. U, V, W and the case (GND) are respectively connected with U, V, W and PE terminals of main return circuit in the drive. The air direction of the cooling fan is from one end of the shaft to the other end.

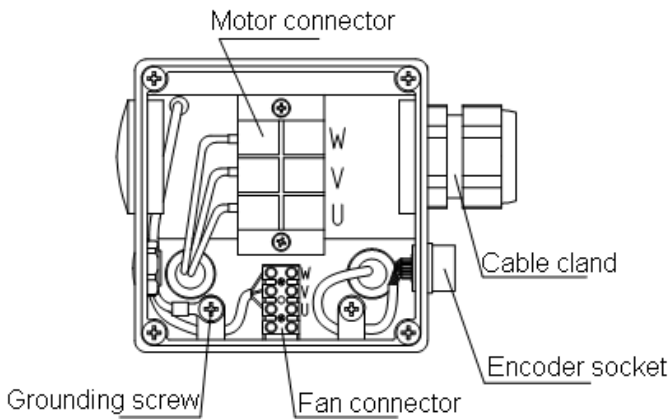

ZJY208A & ZJY265A terminal box

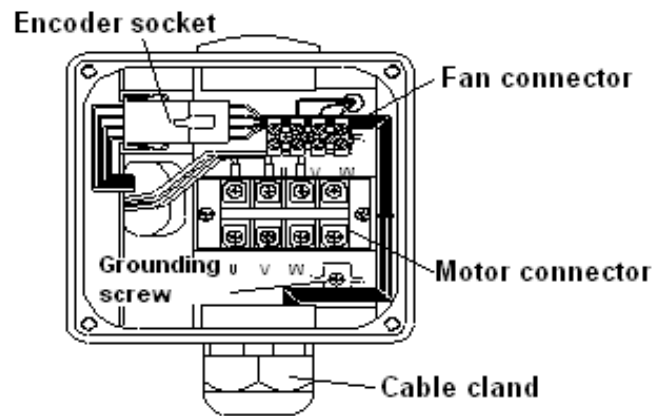

ZJY182 terminal box

6.1.2 Interface of the encoder

6.1.2.1 The incremental encoder lead of ZJY182 series motor is led out by the plug of 12-core connector in the terminal box; about its corresponding relation, refer to list 3. The outlet lead is connected with the plug of the drive feedback signal CN2 based on the drive requirement.

List 3

Encoder lead	Case (GND)	V _{CC}	GN D	A	\bar{A}	B	\bar{B}	Z	\bar{Z}
Socket NO.	1	9	5	6	10	7	11	8	12

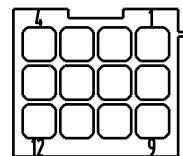

Socket (back) Sketch map

6.1.2.2 The incremental encoder lead of ZJY208A and ZJY265A series motor is led out by the plug of 12-core connector; about its corresponding relation, refer to list 4. The outlet lead is connected with the plug of the drive feedback signal CN2 based on the drive requirement.

List 4

Encoder lead	Case (GND)	V _{CC}	GN D	A	\bar{A}	B	\bar{B}	Z	\bar{Z}
Socket NO.	0	1	2	3	6	4	7	5	8

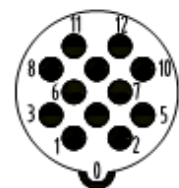

Round connector socket (welding side) sketch map

6.2 Installation of the motor

If the motor should run at the speed above 2000r/min, it's recommended to use the motor of optic axis and the pulley is fixed by the expansion sleeve. And the pulley and the expansion sleeve must reach G1 requirements after the dynamic balancing process; otherwise, the big vibration occurs during running at high speed.

6.2.1 B5 flange installation mode (or use B35 flange installation mode)

ZJY182 series uses M10×35 bolt or HEX screw. During using the HEX screw, the length of the internal hexagonal wrench should be more than the total length of the motor and the wrench can be made by the user. Take down the rubber plug on the fan cover and fasten the screw from the back side, and then, push the rubber plug. (Refer to figure 4)

Use M12×45 bolt or HEX screw on ZJY208A or ZJY265A series motor.

6.2.2 B3 footing installation mode (Or use B35 footing installation mode)

Firstly remove the covers on the sides of back cover during installation. If it is B35 structure, the rubber plug should be also taken down from the footing hole (refer to Fig. 5).

M10×30 HEX screw is used on **ZJY182** and **ZJY208A** series motor and M12×40 HEX screw is used on **ZJY265A** series motor.

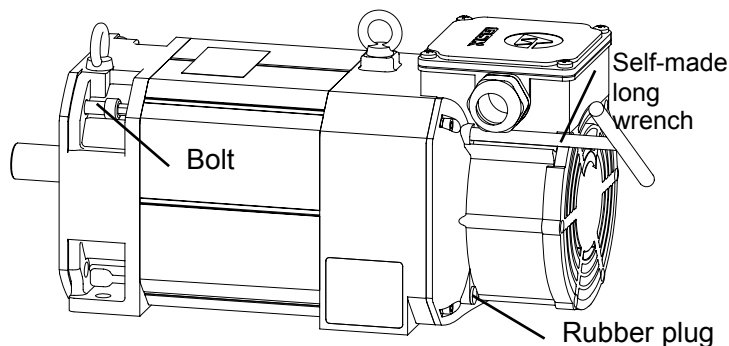

Fig. 4

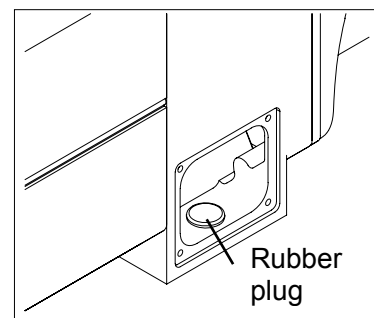

Fig. 5

After fixing the motor, the covers on the sides of the back cover should be installed; otherwise, the cooling will get affected due to air leak, which causes the motor malfunction because of overheat.

VII STORAGE of the MOTOR

The motor should be stored in the room of which temperature should be among $-40^{\circ}\text{C}\sim+70^{\circ}\text{C}$, and the relative air humidity of the storeroom should NOT be more than 95%; Moreover, the storeroom should be clean, ventilated and free of the corrosive gas.

VIII TRANSPORTATION of the MOTOR

The motor should be put carefully and avoid hitting and impacting during transportation. And the corrosion substance, such as the sour and alkali, etc should NOT be put with the motor.

IX WARRANTY

On condition that the motor is transported, stored, installed, debugged and repaired based on the operation regulations, GSK is responsible for the motor repair free in one year from the dispatch date (on the basis of the dispatch voucher) if the motor is damaged or can't be used normally due to the quality.

Note 1: The listed motor modals in the manual are recommended by GSK, which can be used in many situations. If the user has some new requirements, GSK can provide the motor of the other specifications based on your requirements.

Note 2: The basic shaft end of the motor manufactured by GSK is the cylinder shape without the key slot type. GSK can provide the motor with different shaft end types (remark during order), like the cylinder shape with the key slot shaft end (refer to GB/ T 756—2010), based on your requirements.

Note 3: Because the spindle motor speed is very high, the rotary parts should reach the corresponding dynamic balance requirement; otherwise, it causes the big vibration and noise, even the motor and equipment get damaged. When the rotor of the spindle motor is dispatched from the factory, its dynamic balance precision should reach G0.4 at the speed of 6000r/min. And the user should pay attention to the following points:

- ◇ It's recommended to use the spindle motor with the optic axis;
- ◇ The pulley must adopt the dynamic balance processing, and its precision should reach G1 or higher (the amount of unbalance in one side should be less than 50mg.) when the speed is 6000r/min. Moreover, the weight of fixed screws should be same. Compared with the concentricity of the shaft, the installed clamping ring should NOT be more than 0.1mm;
- ◇ If the user has to adopt the key connection method, the pivot axis of dynamic balance should be made based on the spindle motor shaft end and the key dimension and material, and the pivot axis is for the pulley dynamic balance, and the dynamic balance precision is same as above. The pulley can be press mounted through the screw on the bolt hole at the motor shaft end, or the pulley is shrinkage installed, but it's not allowed to hit the pulley.

✧ If the required dynamic balance equipment isn't available for the user temporarily, the user can entrust GSK with the pulley balance processing and installation.